

GEMBOREE 2020

10th to 13th April 2020



Albury Showgrounds

Australia's National Gem, Mineral & Fossil Show

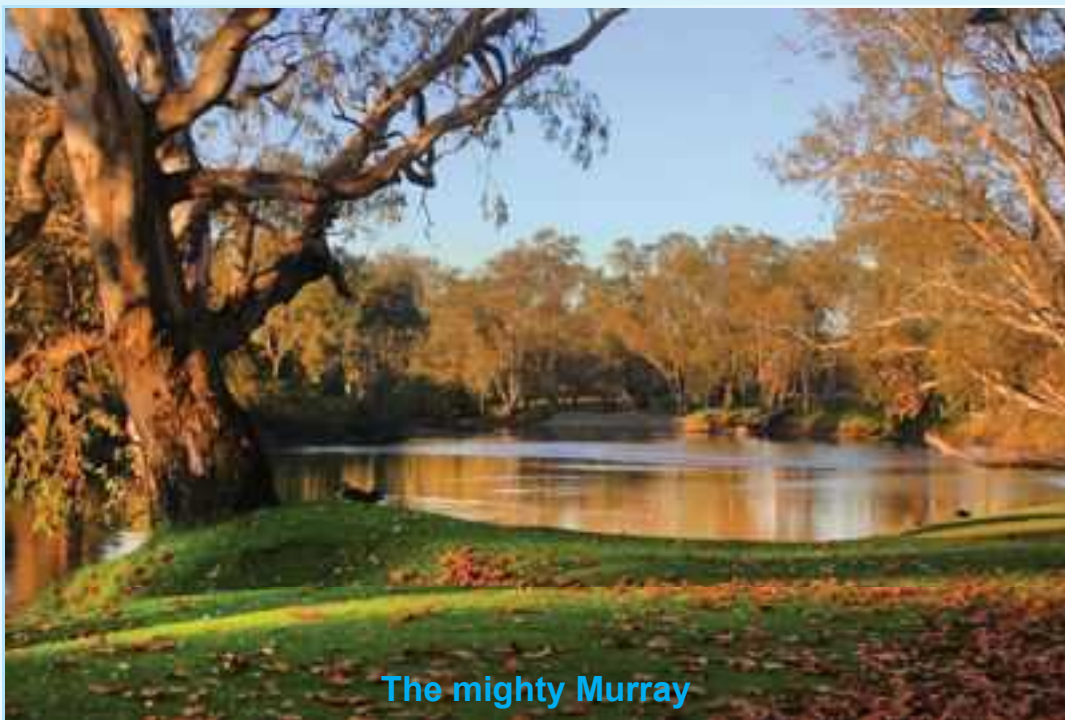

The mighty Murray

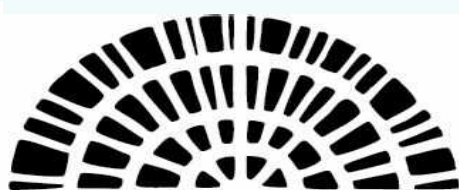

Albury City



Whether it
is your hobby
or business

Knowledge is Vital



Introduction to Gems
and Gemmology

Crystals 101

Pearl Threading

Organics and Ornaments

Jewellery Product Knowledge

Introduction to Antique Jewellery

Synthetic and Gemmology Update

Jewellery Sketching

Jewellery Design

Advanced Pearls

Advanced Opal

Advanced Jade

Rare & Infrequently Encountered Gemstones

Advanced Gemstone Inclusions Course

Diploma of Gemmology

Taught Face to Face, Intensive, correspondence

Diploma of Diamond Technology

Course availability varies in each state

GAA makes
learning fun
& entertaining.
You reap the
benefits.

Enquire today!

info@gem.org.au

www.gem.org.au



GAA

Gemmological Association of Australia

ADELAIDE | BRISBANE | HOBART | MELBOURNE | PERTH | SYDNEY

*Passionately educating the industry, gem enthusiasts
and consumers about gemstones*

DINING OUT

COMMERCIAL CLUB ALBURY



• SPORTS BAR • GRILL •

OPEN 7 DAYS FOR LUNCH 12-2PM AND DINNER 6-9PM
Featuring a diverse modern Australian menu celebrating fresh, natural flavours and food we love to eat ourselves.

The Red Room

OPEN FOR LUNCH & DINNER
*Trading times available from reception with bookings necessary.
Albury's only silver service restaurant.*



SEVENS
BISTRO

OPEN DAILY FOR LUNCH 12-2PM AND DINNER 6-9PM
Features an extensive buffet of seasonal delights together with Bistro Dining.

Reflections Café

OPEN DAILY FOR BREAKFAST THROUGH TO LATE SUPPER
A kaleidoscope of cuisine made from the freshest seasonal ingredients.



WELCOME TO ALBURY



AlburyCity

AlburyCity is absolutely delighted to welcome GEMBOREE 2020 to our beautiful city on the banks of the mighty Murray River on Wiradjuri Country.

Albury along with its Victorian neighbour Wodonga, forms a key regional hub servicing southern NSW and north east Victoria with business, professional and medical services, a thriving hospitality sector, vibrant CBDs and open space precincts.



For those making the trip for GEMBOREE 2020 we encourage you to extend your Easter break to take in the wonderful attractions in Albury and the region. Take in our magnificent gardens and riverside parks, galleries and museums, the world famous wineries of Rutherglen and the King Valley, heritage and history, aboriginal culture, fantastic shopping and amazing food and wine. It's all here.

There's also a range of quality accommodation with over 2,500 rooms ranging from luxury apartments and hotel rooms to cosy B&Bs to caravan parks.

For all information on accommodation and attractions to plan your perfect visit go to our website visitALBURYWODONGA.com or contact the friendly staff at our visitor information centre on 1300 ALBURY.

All that aside, the very best part about Albury is our people! I know our community will warmly welcome you to the city and ensure that you have a memorable and enjoyable stay.

We warmly congratulate our local lapidary fraternity on its wonderful work. Club members contribute enormously to our community taking part in a range of community events to showcase the skill and enjoyment of their craft. The club has mentored juniors and students for more than twelve years ensuring that the art of lapidary is alive and well in our region.

We wish everyone involved a most successful GEMBOREE in Albury 2020.

Cr Kevin Mack
Mayor, AlburyCity



Raffle Prize Sterling Silver & Gold Bracelet

Donated by Cliff Watters and Shepparton and District Gem Club
Sterling Silver – P.W.B (Peter W Beck) oxide resistant
Gold – from nuggets found in “The Golden Triangle”, Victoria
Hand crafted “one of a kind” bracelet.



VICTORIAN GEM CLUBS ASSOCIATION INC.

P.O. BOX 642

RINGWOOD. VIC. 3134

Email vgca1lapidary@gmail.com

Web <http://www.victoriangemclubsassociationinc.com>



Tools for the art of jewellery



AUSTRALIAN JEWELLERS SUPPLIES

AJSONline.com | Phone 1300 852 999

Call or visit for friendly service & expert advice

ADELAIDE | BRISBANE | MELBOURNE | PERTH | SYDNEY

A HISTORY OF ALBURY LAPIDARY & ALLIED CRAFTS- INC. 1964 TO 2019

The inaugural meeting of the Albury and District Lapidary Club was held at Albury High School on 23rd October 1964 and 70 people attended the meeting. The search began for a place to call a home and one was found at Jindera in the old store in March, 1965. When the owner of this building died and the building was sold to the Jindera Museum, the members eventually found a home in a cellar in Wilson Street, apparently next door to where Harvey Norman was, this was on 29th September, 1965. During this time members brought their own chairs to meeting and necessities like cups, mop and bucket etc. were all donated. On the expiry of the lease for the cellar a new home had to be found, this was a brick cement building in the North East Dairy Company on the Lincoln Causeway in June 1969 for the princely sum of \$3 a week.

The Club sought a land grant from the Council and in November 1970 this was granted. As no money was forthcoming from the Council, although Mayor Cleaver Bunton spoke up for the club on many an occasion, a small group of people slaved making lucky dips and travelling around 8 local shows and holding stalls at every conceivable place for 4 years until they had saved enough money to start building. On 27th July, 1973 plans for the building were finished. To get enough money to build it besides what they had made themselves, it was decided to work on an overdraft. The only Bank willing to do this was the Rural Bank and members were asked to put money in the Rural bank on fixed deposit as collateral for the loan. This they did and eventually were able to retrieve their money when the building was paid for. Total cost of the club was about \$10,000 and a Council valuation soon after was \$100,000.

The club was officially opened by Mayor Cleaver Bunton on 14th August, 1976.

On 22nd September, 1987 the club became incorporated and the name was changed to Albury Lapidary and Allied Crafts Incorporated, this was to widen the scope of what could be done within the club.

Negotiations with Albury City Council, Department of Lands and the RTA started in 1998 and continued on and off again until they became a serious issue in the early 2000's. This was a most difficult time for those who were dedicated to the club and had to look after its interests. A subcommittee was formed to look after these interests. At one stage it looked like the club would not have a clubhouse at all as the RTA tried to say

that the club's lease was not valid. The club had lots of problems with Department of Lands, RTA, and the architect. The council backed us and we eventually got the new building, further negotiations brought about the safety fence and the old window guards were put on the new building. With the aid of the Council we got all new fixtures in the club. A few club members and a couple of council workers shifted everything from one building to the other. A few women then painted all the equipment. Silver smithing benches were built by our teacher of 8 years and the President, these were then varnished by the same women.

An open day was held on 11th March 2007 to open the clubrooms and Mayor Amanda Strelec did the honours with Greg Aplin giving a few words of wisdom. A Brass plaque was donated by Albury City Council with Council logo on it. Since then we have celebrated the Club's 50th anniversary. New equipment has been obtained through grants and another shed was built with a grant to house all the saws. Silver smithing has its own room and juniors are still in full swing after 11 years.

Welcome from the GEMBOREE Co-ordinator.

My husband and I have been members of the Albury Lapidary and Allied Crafts Inc. for nearly 40 years, it was originally Albury and District Lapidary Club until it was incorporated. We have filled every position on the committee several times over. We have seen great progress over those years, including a new building and the introduction of juniors under the age of 12 years.

Our son Timothy introduced us to gemstones at the age of three and we then joined the club for his benefit. It was a family tradition until Tim left for ANU to take up geology and paleontology. I co-ordinated the 2013 Gemkhana at Albury and even with a heatwave we ran a very successful show.

We welcome everyone, tailgaters, dealers, competitors, followers of Gemshows, volunteers and the public to come to Albury for this great event. Lavington Lions will be providing a huge range of food and we hope the weather will oblige.

Joan Barrows

Hume Bank

proudly supports

Albury Lapidary and Allied Crafts Inc.



1300 004 863



humbank.com.au

EXPERIENCE

SOCIAL DINING & BAR

FOR AMAZING AND CONSISTENT SERVICE,
GREAT VALUE FOR MONEY, EXCEPTIONAL
FOOD AND DRINK AND ABOVE ALL:
A WELCOMING SOCIAL SPACE.

.....

WE PROVIDE ALL DAY DINING, A RANGE OF
COMFORTABLE SEATING, GREAT COFFEE
FROM 9.30AM PLUS AN EXTENSIVE DINING
MENU FROM 11.30AM UNTIL 9PM SUNDAY
TO MONDAY AND UNTIL 1AM ON FRIDAY
AND SATURDAY NIGHTS.



02 6041 2222 | saclub.com.au

Albury Visitor Information Centre



We'd like to extend a warm welcome to you.

Albury Wodonga has always been a meeting place of two cities, and two states, across the mighty Murray River. Today that proud historic duality has made it a special place with heritage charm and modern sophistication in equal measures.

Here you can cycle along the Murray River, wander through a local farmers market or explore the regions indigenous history as well as the new and emerging food and wine precincts. MAMA, the Murray Art a Museum Albury, and Bonegilla Migrant Experience are also a must see. Treat yourself to some boutique shopping and dine your way through Albury Wodonga's acclaimed restaurants.

The two cities are an inland haven for those travelling with the family. Meet the dinosaurs at the immaculate Albury Botanic Gardens, fly like a fox on the 30m flying fox, jump and climb a morning away at the indoor trampoline and climbing centres. Or, slow down and be creative at the continually changing exhibition at MAMA's and Albury Library Museums that often include children elements.

Whether planning your trip to Albury Wodonga or already in the cities, let the friendly staff at the Albury Visitor Information Centre help make the most of you visit. Located in the historic Albury Railway Station precinct, staff can assist with insider tips, maps, itineraries, accommodation and information on local and regional attractions.



It's all here and ready to be experienced, side by side

Albury Visitor Information Centre
Railway Place, Cnr Smollett and Young Streets, Albury NSW1300
ALBURY (1300 252 879)

info@visitALBURYWODONGA.com
www.visitALBURYWODONGA.com



visit ALBURYWODONGA.com

see both sides

ALBURY-WODONGA

ALBURY-Wodonga has long been popular for gatherings of all kinds, so it is a natural location for a GEMBOREE. A riverside reserve is called Mungabareena, a “place of plenty big talk.” Here the Wiradjuri and other language groups gathered for corroborees, talking and trading. Human occupation in these parts began perhaps 35,000 to 40,000 years ago.

Today Albury-Wodonga’s combined population is more than 90,000. It is the 20th largest urban centre in Australia (The two municipalities were officially designated “One Community – Two Cities” in 2017).

Among the residents are more than 2400 people with Aboriginal or Torres Straits Islander heritage. They come from language groups all over Australia who were resettled from the 1970s onwards. Albury is an English name, but Wodonga a native word meaning “bulrushes”. Locality names like Bandiana, Baranduda, Ettamogah and Thurgoona are enduring legacies of the first people.

Europeans did not arrive until 1824. In that year, Wiradjuri warriors lost a war near Bathurst with British settlers and soldiers. Within weeks, Governor Thomas Brisbane commissioned an exploration of the unknown bush between the Southern Highlands and the Victorian coast. Hamilton Hume, William Hovell and six convicts found a route to the southern ocean, encouraging white settlers to move further from Sydney to establish sheep and cattle stations and, in doing so, to drive away the indigenous inhabitants.

Hume and Hovell’s route from Appin brought them to the Murray at Albury. They trekked on to Corio Bay. Over the next decade, a track linking Sydney with Melbourne was developed largely on the explorers’ route.

Albury began as a permanent white settlement about 1835. Wodonga followed a few years later. Squatters established stations either side of the Murray, one called Mungabareena, another Wodonga. An Irishman, Robert Brown, built Albury’s first store and later a hotel by the Hovell Tree, and started a punt ferry.

In 1838, there was a clash between Aborigines and settlers at the future site of Benalla. Several Europeans were speared and far more native people were shot in reprisals, the affair being known as the Faithful Massacre. An anxious government established Border Police posts at Albury and Benalla to protect travellers and squatters from Aborigines and bushrangers.

Once Albury was declared a township in 1838, timber and brick dwellings appeared. A surveyor’s map noted the native name was Bungambrawartha, but a Sydney official altered to “Albury”.

Gold was found in Albury’s Black Range in 1851 and in Beechworth, Bright and Buckland areas in 1852. Albury’s gold was not deemed viable to mine on a grand scale, but thousands of European and Chinese men set up tent towns in North East Victoria’s rich fields.

Albury boomed as a crossing place, a customs post and a supplier of goods and services. About 600 people were living here when the first paddlesteamer from South Australia arrived in 1855 and the first newspaper began in 1856. From 1859, Albury elected its own council and mayor. The Murray was bridged in 1861 and Albury soon gained a court house, a hospital and a jail. A quarry on the Howlong road produced granite ideal for buildings and foundations. (See the old Court House in Dean Street, St Matthew’s and St Patrick’s churches and Kia Ora in Townsend Street). Wodonga village had its own customs post and police station.

District farms produced mainly wool, wheat and wine. German and Chinese settlers grew vegetables and tobacco. The Victorian railway reached Wodonga in 1873. Ten years later the southern line reached Albury from Sydney. In 1885 the two systems were linked over the Murray, though with different gauges. The 1880s saw Albury gain its own water supply system and a gasworks. By Federation in 1901, Albury had 6000 citizens and was short-listed as a possible Australian capital.

After World War I, construction of the Hume Dam provided jobs for returned soldiers. Another 1920s major project creating jobs was the Amalgamated Textiles mill, and Albury consolidated its position as one of Australia’s great wool-selling centres. The Regent Theatre is a superb art deco monument to the 1920s era, as is the Albury War Memorial.

World War II saw Albury and Wodonga become virtually garrison towns, with vast camps for training and logistic units. The military presence continued after the war at Bandiana and Bonegilla. The latter base became a migration centre in 1947 and was the first Australian migration centre to house about 320,000 migrants before it closed in 1972.

Wodonga grew in the 1950s and 1960s due to these camps, the busy livestock saleyards and

new factories. In 1967 Wodonga welcomed Uncle Ben's, now Mars Petcare, where at times the workforce has exceeded 900.

Prime Minister Gough Whitlam's decentralisation policies in 1973-74 saw Albury-Wodonga become Australia's first designated National Growth Centre. Its initial population target of 300,000 by 2000 was halved under the Fraser government and abandoned in 1989. Nevertheless, the Albury-Wodonga Development Corporation lasted 40 years. It created 6000 home sites on well-planned estates, industrial and public parks, planted millions of trees and sold land for universities and TAFE campuses. Thurgoona and Baranduda were planned as satellite cities. With Leneva, they remain the main growth areas today. In the 1970 and 1980s, Albury gained the Borg Warner gearbox factory and a newsprint mill, now Norske Skog, and diverse manufacturing industries. Until the 1980s, both Albury and Wodonga had large railway staffs. Since then, health and education services have grown

enormously. Both have TAFE institutes, while the Charles Sturt and La Trobe campuses began in Albury and Wodonga in 1989. There is also a medical campus of the University of NSW. The region has a single Albury-Wodonga Health Service with two large public hospitals, as well as a Regional Cancer Centre, the Mercy Hospital and Albury-Wodonga Private Hospital.

Dean Street, Albury, was long the chief shopping area, but today there are malls in central Albury, Lavington, central Wodonga, Thurgoona and White Box Rise.

World famous tennis champion Margaret Court is Albury-Wodonga's best-known daughter. Other former residents range from singer Lee Kernaghan and actor Richard Roxburgh to another world-class sportswoman, basketballer Lauren Jackson. Lauren won gold and silver galore and was, of course, an Opal!

Written as a favour by Howard Jones for the 2020 GEMBOREE.

WOLF'S GEMS

Wholesale and Retail

By Appointment:

10am to 5pm

Monday to Friday

67 Clarke Ave,
St. Albans, Vic.

Mobile:

0402 444 362

- Ready Made Jewellery
- Faceted Gemstones
- Mineral Specimens
- Rough Gems for Faceting
- Opals
- Cabochons
- Beads
- Findings



THANKS FOR YOUR SUPPORT

The VGCA wishes to thank all those who have contributed so far and those who will contribute in the future.

First & foremost our hosts, the Albury and district lapidary club and Albury City Council, who are particularly supportive of our event.

Thank you to all the advertisers who have made the printing of the booklet possible. Please support those that support us. Thinking of eating out during the GEMBOREE then consider the Commercial Club or Social Dining & Bar, their support makes events like the GEMBOREE possible.

To all those who have contributed time and effort in submitting articles, proof reading and offering suggestions thank you.

An early thank you to the volunteers who will help make GEMBOREE 2020 a success

Also a big thanks to the many traders who have already committed to 2020. As this booklet goes to print all inside trading space is taken, however the booklet goes to print over a year before the event so slots may become available, so if interested let us know.

The VGCA still believes there should be a place at shows for the ordinary club member to dispose of excess material. As a result we have commercial & non-commercial tailgating. Obviously, there is an element of trust involved, we hope that our trust in the integrity of people applying to tailgate will not be abused.

Running a GEMBOREE or other significant event relies not only on the enthusiasm and energy of the organising team but also on having sufficient funds and successful marketing of the event. This is where every club, trader and anyone else who reads this booklet can contribute.

Spread the news, check the Facebook page, seek support, enter the competition and plan to come to

THE 56TH ANNUAL NATIONAL GEMBOREE, Albury, EASTER, 2020.

2020 Organising Committee & Contacts.

Gemboree 2020 Co-ordinator

Joan Barrows
Mobile 0488440493
Email joaba99@bigpond.com

Gemboree Treasurer

Wendy Bergamin
Email vgca1lapidary@gmail.com

Gemboree Hall Manager

Carol Kirby
Mobile 0411055297
Email beadbox.carol@gmail.com

Competition Manager

Peter Krake
Phone 03 5825 2778
Email landpkrake@netspace.net.au

Camp Site Managers

Ray and Joy Medew
Mobile 0417269650
Email rjmedew@gmail.com

Gatehouse Co-ordinator

Gwen Dunstan, Waverley Gem Club
Mobile 0407 512 883

Tailgating Co-ordinator

Mike Quinn Nunawading Gem Club
Mobile 0409 091 520
Email pointer.vgca@gmail.com

Judges Co-ordinator

Carol Kerslake
Email carolscollection@hotmail.com

A special thankyou.

To Jordan Bergamin who produced the
GEMBOREE 20 Logo.

A&E METALS

EXCLUSIVE AUSTRALIAN
DISTRIBUTOR OF
ARGENTIUM®



A&E Metals branded range of silver and industrial related precious metal products is the only Australian mass produced range of silver based fabricated metal products.

A&E METALS
A PALLION COMPANY

A&E METALS HEAD OFFICE

68 Smith Street Marrickville NSW 2204 Australia

P: +61 2 8568 4200 | F: +61 2 8568 4240 | E: info@aemetal.com.au

AUSTRALIA WIDE
1300 360 598

aemetal.com.au



GEMBOREE 2020 REGISTRATION FORM

MAIL TO: GEMBOREE 2020, PO Box 642, Ringwood, Vic 3134.

email: vgca1lapidary@gmail.com

(Please enclose stamped, self addressed envelope for return of receipt if no email.)

OR Link to register on Line at www.victoriangemclubsassociationinc.com

NOTE: Registration covers from noon Wednesday 8th April to noon Tuesday 14th April 2020. No refunds for cancellations after 1st February 2020, except in unusual circumstances. Earliest entry to Campsite is 12 noon Wednesday 8th April, Sites **MUST** be vacated by 12 noon Tuesday 14th April 2020. Pets are permitted, owners shall be responsible for their conduct. **GENERATORS ARE NOT PERMITTED.**

VENUE ADDRESS: Showgrounds. (Map & arrival details page 54)
Fallon Street,
ALBURY.

(Please Print Clearly)

Surname: **Given Names:**

Address:

Postcode: **Phone:** **Mobile:**.....

Email:..... **Club:**

CAMPSITE ACCOMMODATION: Be sure to indicate whether you have an annexe.

CARAVANm X m ANNEXEm X m (YES/NO)

CAMPERm X m ANNEXEm X m (YES/NO)

TENTm X m

CLOSE to TOILETS (YES/NO) DISABILITY (YES/NO)

ON-SITE FEES: For 2 Adults & up to 4 Children (school age). Sites approx. 6m x 9m

POWERED SITE \$150.00 \$

UNPOWERED SITE \$130.00 \$

EXTRA VEHICLE \$5.00 \$

EXTRA ADULTS No..... @ \$25.00 \$

EXTRA CHILD (10-16yr) No..... @ \$5.00 \$.....

Air Conditioners, Radiators, Electric Jugs, Frypans & Microwaves

ARE PERMITTED, BUT as with any caravan park, **DON'T HAVE TOO MANY ON AT ONCE.**

Caravanners, please fill your water tanks prior to arrival on site.

Two course dinner (Saturday night) \$25. Pay at the GEMBOREE Office on Good Friday.

OFF-SITE FEES: Per person for duration of GEMBOREE.

ADULTS No..... @ \$30.00 \$

CHILDREN (10-16yr) No..... @ \$5.00 \$.....

SOUVENIRS:

GEMBOREE BADGES No..... @ \$6.00 \$.....

TOTAL \$.....

Payment Method (Underline method) Cheque/money order enclosed OR Direct Deposit

Please make all cheques/Money Orders payable to:
"Victorian Gem Clubs Association Inc. GEMBOREE Account"

Direct deposit; (Bendigo Bank)

Account name; Victorian Gem Clubs Association Inc. GEMBOREE Account;

BSB (633-000) Account number; (118719624) **Be sure to include your name as reference.**



VOLUNTARY ASSISTANCE AT GEMBOREE 2020

MAIL TO: GEMBOREE 2020, PO Box 642, Ringwood, Vic 3134

To arrive no later than January 31st 2020

Or email: joaba99@bigpond.com

Please offer some of your time to help make the GEMBOREE more enjoyable for everyone. Your help will be greatly appreciated. Please indicate below which areas, days and times you are willing to assist. The major areas in which we need help are (Please tick):

- **CAMPSITE MARKING etc** - From Tuesday 7th April.
- **CAMPSITE GATES** - From noon Wednesday.
- **EXHIBITION SETTING UP** - From Wednesday am.
- **EXHIBITION DOORS** - From 9.30am Friday to Monday closing.
- **EXHIBITION HALL STEWARD** - During opening hours of the Show.
- **EXHIBITION DISMANTLING.**
- **CAMPSITE CLEAN-UP, TRESTLE LOADING etc.**
- **OTHER ASSISTANCE - Please specify**.....

<input type="checkbox"/>
<input type="checkbox"/>
<input type="checkbox"/>
<input type="checkbox"/>
<input type="checkbox"/>
<input type="checkbox"/>
<input type="checkbox"/>
<input type="checkbox"/>

.....
(Please Print Clearly)

Surname: **Given Names:**

Address:

Postcode: **Phone:** **Mobile**.....

Email:.....

Area(s) where you are offering to help:

.....

.....

.....

.....

.....

Times you are available, between Tuesday 7th April to Tuesday 14th April 2020:

.....

.....

.....

.....

.....

ALBURY SERVICES

- AMBULANCE/ FIRE/ POLICE Call 000 or Mobile 112
- HOSPITAL: Albury Hospital, Borella Road, Albury.0260584444
- CHEMISTS: Mayo's Pharmacy, Myer City Centre, David Street, Albury.
Discount Pharmacy, Olive Street, Albury.
Mate Street Pharmacy, 1089 Mate Street, Albury Nth.
- POLICE STATION: Olive Street, Albury.
- POST OFFICES: Centro Lavington, Griffith Road, Lavington.
Kiewa Street, Albury.
- SERVICE STATIONS: Ampol, David Street Albury.
Caltex, Wagga Road, Lavington.
BP, Wagga Road, Lavington.
Shell, Hume Street, Albury.
Independent, Mate Street, Albury.
- CHURCHES: City Central Church, David Street, Albury.
Anglican Church, 520 Kiewa Street, Albury.
Catholic Presbytery, 515 Smollett Street, Albury.
Baptist Church, 152 Benyon Street, Albury.
Presbyterian Church, 402 Wagga Road, Albury Nth.
Seventh Day Adventist, 805 David Street, Albury.
Salvation Army, Cnr Corella/Union Roads, Albury Nt.h
- SUPERMARKETS/
SHOPPING CENTRES: Myer City Centre, David Street, Albury.
Centro Lavington, Griffith Road, Lavington.
Centro Albury, Kiewa Street, Albury.
Aldi Stores, Hume Street, Albury, Centro Lavington.
IGA, Borella Road, Albury.
- RESTAURANTS: Large selection, gourmet to take-away, i.e.Indian, Thai, Mexican, Chinese.
Steak houses, Italian, Pizza, KFC, Kentucky, Red Rooster, Fish and Chips.
- ENTERTAINMENT: Clubs: SS&A Club, Olive Street, Albury.
Commercial Club, Dean Street, Albury (both clubs have meals).
Cinema, Dean Street, Albury.
- ATM'S: At the showgrounds. All the shopping centres listed above, multiple outside banks in Dean Street.

Janice Krause & Chris Ah Yee

HAMILTON, Victoria. 3300

Ph Home: 03 55712753 Mobile: 0438 712753

E-Mail: cjyee@bigpond.com

Specialising in:

***** Australian & Overseas Fossils *****

**** Australian & Overseas Minerals ****

websters

TRUSTED ADVISERS SINCE 1987

Official Insurance Brokers to Gemboree 2020

We are proud to be the official insurance broker for the **Gemboree 2020** and continue to enjoy the support of most Australian gem & mineral clubs.

Websters is a privately owned insurance broking firm that has been providing broking & risk management services Australia wide for over 30 years.

For all your insurance needs **Contact Us**

08 8362 5553 | info@websters.com.au | www.websters.com.au

TOP QUALITY AUSTRALIAN and OVERSEAS FOSSILS

(Including Ex COWIE Collection)

**OPAL fossils from Coober Pedy
and
Good quality Walsh River Fossils**

**AFRICAN, AUSTRALIAN and OVERSEAS MINERALS and CRYSTALS
Including Special, Rare CAJEBUT, W.A. Minerals**

Contact: Michael and Coralie FISHER:-

Phone: 0438 327 406 or 0428 327 404

Email: micol@adam.com.au

Gemcuts

*Lapidary * Fossicking
* Jewellery Making Tools



Cabbing



Tumbling



Jewellery Tools



Carving



Sawing



Ultrasonic Cleaners

We stock an extensive range of our own diamond tools, faceting accessories, rough and products.

We are Authorised dealers for:

Diamond Pacific Tool Corp – Nova, Genie, Bigfoot, Galaxy

Barranca - MK Diamond Saw Blades

Lortone - Cabbing Machines, Saws, Rotary Tumblers

Saeshin - "Strong" Micro Motors

Cratex - Rubberised Abrasives

Crystalite - Diamond Laps, Crystal Pads, Poly Pads, Flexo Pads

Klingspor - Industrial Grade Sanding Sheets, Belts & Disks

GemPro - Flex Wheels, Resin Bonded Diamond Products

Jersey Instruments – Faceting Machines

36A Smith Drive
Ballina NSW 2478
Ph. 02 66811686
A/H 0427 012 014
Brian & Liz

MAIL
PHONE &
INTERNET
ORDERS

www.gemcuts.com.au

COMMERCIAL TAILGATING - Terms and Conditions

1. I will abide by the following terms and conditions to Tailgating at the 'Event'.
2. I will sell only items or material, which will be of a lapidary nature or lapidary related.
3. I will trade only within the times and areas allotted to me by the 'Event' Organisers.
Tailgating sites to be cleared at end of trading times each day. Camping prohibited in tailgating area.
4. I will trade in a respectful manner at all times and follow instructions from the organising committee.
5. Application to Tailgating does not entitle me to trade, except upon acceptance by the 'Event' Organisers and receipt of the Booking Ticket which becomes my Permit to Trade.
6. A copy of my Public Liability Insurance cover with a minimum cover of \$20M that will be valid (or renewed) at the time of this event will be emailed to the organisers within 14 days of placing my booking.
7. Applications and Bookings lodged without supplying a copy of the Insurance Policy or Certificate of Currency within 14 days may be rejected and therefore cancelled with a full refund less any 'booking fees' paid.
8. Bookings cancelled up until 2 months prior to the 'Event' will receive a full refund less any 'booking fees' paid. Any cancellations made within 2 months prior to the 'Event' without good reason will forfeit any 'booking fees' paid plus all or part of their Tailgating fees paid.
9. If I contravene any part of these terms I agree to vacate the 'Event' site and forfeit all monies paid.

PRIVATE TAILGATING - Terms and Conditions

1. I will abide by the following terms and conditions to Tailgating at the 'Event'.
2. I am a Hobbyist and do not earn monies from any Commercial/Semi-commercial phase of the Hobby, e.g. Mining, Dealing, Full-time cutting or Manufacture. I will not make credit card facilities available.
3. I will sell only material which is surplus from my Hobby activities, e.g. Field collecting, upgrading my collections and/or items made" by me and which will be of a lapidary nature or lapidary related.
4. The material for sale has not been purchased specially for resale, except for commercially made findings used in jewellery making.
5. I will trade only within the times and areas allotted to me by the 'Event' Organisers.
Tailgating sites to be cleared at end of trading times each day. Camping prohibited in tailgating area.
6. I will trade in a respectful manner at all times and follow instructions from the organising committee.
7. Application to Tailgating does not entitle me to trade, except upon acceptance by the 'Event' Organisers and receipt of the Booking Ticket which becomes your Permit to Trade.
8. A copy of my Public Liability Insurance cover with a minimum cover of \$20M that will be valid (or renewed) at the time of this event will be emailed to the organisers within 14 days of placing my booking.
9. Applications and Bookings lodged without supplying a copy of the Insurance Policy or Certificate of Currency within 14 days may be rejected and therefore cancelled with a full refund less any 'booking fees' paid.
10. You may cancel your booking up until 2 months prior to the 'Event' for a full refund less any 'booking fees' paid. Any cancellations made within 2 months prior to the 'Event' without good reason will forfeit any 'booking fees' paid plus all or part of their Tailgating fees paid.
13. If I contravene any part of these terms I agree to vacate the 'Event' site and forfeit all monies paid.

NOTE:

1. Places will be allocated on a first come first in basis.
2. Do not turn up on the day expecting to Tailgate. No booking no tailgating.



GEMBOREE 2020

APPLICATION FOR COMMERCIAL TAILGATING SPACE

MAIL TO: GEMBOREE 2020, PO Box 642, Ringwood, Vic 3134

Email: POINTER.VGCA@gmail.com

(Please enclose stamped, self addressed envelope for return of receipt if no email.)

I wish to apply for Commercial Tailgating space during GEMBOREE 2020 at the Albury Show Grounds. I have read the terms and conditions and agree to abide by them.

(Please Print Clearly)

Surname: Given Names:

Address:

Postcode: Phone: Mobile.....

Email:.....

Please circle the days you wish to Trade

Friday 10th April		Saturday 11th April		Sunday 12th April		Monday 13th April
----------------------	--	------------------------	--	----------------------	--	----------------------

FEES: \$75 per day or part there of for a 3 metres frontage with one metre between sites or \$275 for the four days.

Payment: Sites approx. 3m x 9m with 1 metre between sites

Tailgating FeeDay/s	@ \$75 per day	\$
	OR 4 Days	@ \$275	\$
Extra Sites X.....Day/s	@ \$75 per day	\$
 X for 4 Days	@ \$275	\$
Registration Fee.....People X.....Day/s		@ \$8 per day	\$.....
(Per Adult if you have not registered a Campsite or as staying off site.)			
Total Enclosed			\$.....

Declaration: I have attached a copy of my public liability insurance policy with a minimum cover of \$20 million that will be valid at the time of the event. I have **read** and will abide by the **Terms and**

Conditions.

Signed:.....**Date:**.....

Payment Method (Underline method) Cheque/money order enclosed OR Direct Deposit

Please make all cheques/Money Orders payable to:
"Victorian Gem Clubs Association Inc. GEMBOREE Account"

Direct deposit; (Bendigo Bank)

Account name; Victorian Gem Clubs Association Inc. GEMBOREE Account;

BSB (633-000) Account number; (118719624) **Be sure to include your name as reference.**

Enquiries: Mike Quinn (Tailgating Coordinator) Phone 0409091520

Email: pointer.vgca@gmail.com

Website:www.victoriangemclubsassociationinc.com



GEMBOREE 2020

APPLICATION FOR PRIVATE/ NON-COMMERCIAL TAILGATING SPACE

MAIL TO: GEMBOREE 2020, PO Box 642, Ringwood, Vic 3134

Email: POINTER.VGCA@gmail.com

(Please enclose stamped, self addressed envelope for return of receipt if no email.)

I wish to apply for Private/ non-commercial Tailgating space during GEMBOREE 2020 at the Albury Show Grounds. I have read the terms and conditions and agree to abide by them.

(Please Print Clearly)

Surname: **Given Names:**

Address:

Postcode: **Phone:** **Mobile:**.....

Email:.....

Please circle the days you wish to Trade

Friday 10th April		Saturday 11th April		Sunday 12th April		Monday 13th April
----------------------	--	------------------------	--	----------------------	--	----------------------

FEES: \$50 per day or part there of for a 3 metres frontage with one metre between sites.

Payment: Sites approx. 3m x 9m with 1 metre between sites

Tailgating FeeDay/s	@ \$50 per day	\$
Extra SitesX.....Day/s	@ \$50 per day	\$
Registration Fee.....People X.....Day/s		@ \$8 per day	\$.....
(Per Adult if you have not registered a Campsite or as staying off site.)			
Total Enclosed			\$.....

Declaration: I have attached a copy of my public liability insurance policy with a minimum cover of \$20 million that will be valid at the time of the event. I have **read** and will abide by the **Terms and Conditions.**

Signed:.....**Date:**.....

Payment Method (Underline method) Cheque/money order enclosed OR Direct Deposit

Please make all cheques/Money Orders payable to:
"Victorian Gem Clubs Association Inc. GEMBOREE Account"

Direct deposit; (Bendigo Bank)

Account name; Victorian Gem Clubs Association Inc. GEMBOREE Account;

BSB (633-000) Account number; (118719624) **Be sure to include your name as reference.**

Enquiries: Mike Quinn (Tailgating Coordinator) Phone 0409091520

Email: pointer.vgca@gmail.com

Website:www.victoriangemclubsassociationinc.com

Metal Stone & Glass Magazine

PO Box 2557
Graceville East, Qld 4075
0404 94 5177

subs@metalstoneandglass.com.au
www.metalstoneandglass.com.au

One year (2 issues) for Aus. \$16.00 2 years \$30.00
N.Z. Asia Pacific 1 year \$23.00AUD 2 years \$42.00
USA/Europe rest of world \$30.00AUD 2 yrs \$55.00

Name _____

Address _____

City _____ State _____ PC _____

Country _____ Ph _____

Email _____

Payment by Credit Card Cheque Money Order M/C Visa

Number _____ / _____ / _____

Expiry _____ / _____

As of January, 2018 Metal Stone and Glass magazine is available by subscription only, as a digital or print edition, a complete library of back issues is available through our website.

Robilt Lapidary Supplies

167 Endeavour Drive North Cranbourne Vic. 3977

P. O. Box 179 Doveton Victoria 3177

Ph : (03) 5996 0750 Fax : (03) 5995 7505 Mob : 0414 469 203

ABN 37 856 874 788

Email : robilt@unite.com.au

Manufacturers of Lapidary Machines for over 45 years.

Tumblers - Trimsaws - Slabsaws - Grinders - Polishers

Vibro Laps - Flat Laps - Faceting & Combination Machines

Suppliers of Grits - Laps - Wheels - Blades - Dops - Discs

Service - Repairs - Spare Parts - Rough - Cut - Polished Stones

Servicing Your Lapidary Needs

“QUALITY GEM ROUGH SUPPLIES”

(Glenn Huntley)

**Finest quality faceting rough in
both natural and synthetic
material**

***Faceted Stones
In
Free Shape
&
Calibrated Sizes***

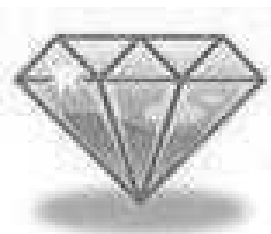

Opal Rough

Opal Solids

Triplets

**Bankcard, MasterCard & Visa
accepted**

**Box 3841, Marsfield, N.S.W. 2122
Phone 02 9888 1261 Fax 02 9888 1063**

Mobile 0427 945 087

Email: qualitygemrough@gmail.com

2020 GEMBOREE COMPETITION SCHEDULE

THIS IS A LEVEL 4 COMPETITION.

GENERAL CONDITIONS:

- 1 All Sections will be judged in accordance with the rules and conditions of the “Competitor and Judging Manual for Lapidary and Allied Competitions” issue No. 8 April 2015 (referred to as the Manual in this Competition Schedule), unless otherwise stated in this Schedule.
- 2 **ENTRY FORMS, POSTAL ENTRIES** and all enquiries relating to this competition should be sent to:

The Competition Committee
PO Box 500
MOOROOPNA VIC 3629
Email: Peter at landpkrake@netspace.net.au
- 3 **ENTRY FORMS:**
ENTRY FORMS for all Sections must be received by The Competition Committee by Friday 31st January, 2020 together with a flat entry fee of \$5 per competitor. A stamped, self-addressed envelope for return of receipt must be sent with the entry form. Entries on a late Entry Form will be for Display Only. Entries from overseas competitors will be free.
- 4 **ACTUAL ENTRIES:**
ENTRIES in Sections 1, 2, 3, 4, 7, 8, 9, 10, 11, 12, 13, 14, 18, 19, 20, 21, 24, 25, 26A and 26B will be judged before the GEMBOREE. They must be mailed to reach the Competition Committee by Friday 31st January, 2020. It is recommended that all mail entries be sent by Registered or Express Post.
Late entries will not be eligible for competition: they will be for Display Only.
ENTRIES in Sections 5, 6, 16, 17, 26C, 27, 28, 29, 31, 32, 34, 37 and 99 will be judged at the GEMBOREE. Entries must be delivered to the Competition Committee at the Gem Show Hall between 2 pm and 5 pm on Thursday 9th April, 2020. Approximate dimensions (in cm) must be entered onto the Entry Form for these entries to be eligible.
- 5 **RETURN OF ENTRIES:**
The preferred method for the return of entries should be stated on the Entry Form and, if necessary, sufficient funds to cover this return must be included with the entry fee.
Registered or Express Post is recommended.
- 6 Cheques and Postal Orders are to be made payable to:

“Victorian Gem Clubs Association Inc. GEMBOREE Account”
- 7 Competitors are advised to check their eligibility to enter a Novice or Intermediate Section. If in doubt, your status can be verified by checking on the AFLACA Competition Winners List on the AFLACA website: <http://aflaca.org.au/judging-rules/competitors/>
- 8 A maximum of two entries per person per Section is allowed except for Showcase sections where only one entry per person is allowed.
- 9 The Competition Committee may transfer an entry into its correct Section if they are of the opinion that it has obviously been entered in the wrong section.
- 10 **OVERSEAS ENTRANTS**
 - Overseas entrants will be deemed to be “Open Division” competitors unless they are a junior competitor
 - Will not be charged an entry fee due to the high costs associated with currency exchange
 - Are advised to include a copy of their entry form and clearly label their package “Lapidary Competition Entries – to be returned”. It is suggested that a high monetary value should not be stated in any paperwork to avoid possible problems with Customs
- 11 While every care will be taken, the GEMBOREE Committee will not accept any responsibility for any loss or damage of competitive or non-competitive entries/exhibits that may occur in transit

or while in the possession of the GEMBOREE Committee.

- 12** Competitors are responsible for insurance of their entries while in transit and while in the possession of the GEMBOREE Committee.
- 13** Judging Sheets will be available for collection between 3.00 pm and 5.00 pm on Saturday 11th April 2020. Judging sheets not collected will be returned with the actual entries.
- 14** Entries can be collected between 3.30 pm and 5.00 pm on Monday 13th April 2020. Entries not collected at this time will be returned to the competitor in the manner specified on the entry form.

SPECIAL CONDITIONS:

- A SIZES and TOLERANCES:** Where an entry does not conform to the size conditions and tolerances set out in this Schedule or the Manual, it will be ruled Ineligible and For Display Only. Where a minimum size hole is specified the measuring gauge must be at least 10 mm thick.
- B** To be Eligible, the Entry **MUST** accurately represent the design depicted on the supplied cutting diagram and comply with the Material Specifications.
To be Eligible, coloured stones **MUST** be obviously coloured while colourless stones **MUST** show no sign of colour. Entries will be checked by viewing through the culet when placed on a piece of standard white copy paper.
- C** Eligible Showcases will be numbered, with the winner being decided by a public ballot held during the show.

COMPETITION SCHEDULE:

O = Open **I** = Intermediate **N** = Novice **J** = Junior **C** = Craftsmanship

AA = Aesthetic Appeal **SC** = Special Conditions **PT** = Perpetual Trophy **AT** = Annual Trophy

GROUPS 1 AND 2 CABOCHON CUTS (Special Condition A)

Minimum size – 20mm on the longest dimension across the outline shape. All standard cabochons and double standard cabochons must have a definite “Oval Shape”. Unless otherwise specified in the schedule, any Natural Lapidary Material may be used.

Section	Description	Material
O.1A/C	Standard Cabochon	Agate
I.1A/C	Standard Cabochon	
N.1A/C	Standard Cabochon	
J.1A/C	Standard Cabochon	
O.1A/AA	Standard Cabochon	Petrified Wood
I.1A/AA	Standard Cabochon	Petrified Wood
N.1A/AA	Standard Cabochon	Petrified Wood
J.1A/AA	Standard Cabochon	Petrified Wood
O.1B/C	Fancy Cabochon	Obsidian
I.1B/C	Fancy Cabochon	Obsidian
N.1B/C	Fancy Cabochon	
J.1B/C	Fancy Cabochon	
O.1B/AA	Fancy Cabochon	Agate
I.1B/AA	Fancy Cabochon	Agate
N.1B/AA	Fancy Cabochon	Agate
J.1B/AA	Fancy Cabochon	Agate
O.2A/C	Double Standard Cabochon	Coloured, Transparent Quartz
I.2A/C	Double Standard Cabochon	
N.2A/C	Double Standard Cabochon	
O.2B/C	Double Fancy Cabochon	
O.2B/AA	Double Fancy Cabochon	

I.2B/AA	Double Fancy Cabochon
N.2B/AA	Double Fancy Cabochon

GROUP 3: FREE FORMS (Special Condition A)

Minimum size – The dimension specified is the diameter of a circular hole through which the entry MUST NOT be able to be passed through.

Section	Description	Material
O.3/C	Free Form	Solid Opal – 10mm
I.3/C	Free Form	Agate – 15mm
N.3/C	Free Form	Agate – 15mm
J.3.1/C	Free Form	Any Material
J.3.2/C	Free Form	Solid Opal – 10mm
O.3/AA	Free Form	Jasper – 25mm
I.3/AA	Free Form	Any Material – 15mm
N.3/AA	Free Form	Any Material – 15mm

GROUP 4: OPAL (Special Condition A)

Minimum size – 10mm on the longest dimension across the outline shape.

Section	Description	Material
O.4B/C	Opal Doublet – Domed Top	Opal
N.4B/C	Opal Doublet – Domed Top	Opal

GROUP 5: CARVING – Any Hardness

Section	Description	Material
O.5A	Fully 3-Dimensional	
I.5A	Fully 3-Dimensional	
N.5A	Fully 3-Dimensional	
J.5A	Fully 3-Dimensional (MUST be of a “Known Form”)	
O.5B	Carving In Relief	
N.5B	Carving In Relief	

GROUP 6: SCRIMSHAW

Section	Description	Material
O.6	Scrimshaw	
N.6	Scrimshaw	

GROUP 7: SPHERE

Minimum size 30mm on the shortest dimension across the outline shape

Section	Description	Material
O.7A/AA	Sphere	
N.7A/AA	Sphere	

GROUPS 8, 9, 10 and 11 FACET CUTS (Special Condition B)

Section	Description	Material
N.8A	Standard Round Brilliant – Continuous Girdle	Colourless Topaz
O.8B	Standard Round Brilliant – Faceted Girdle	Specified Size 8mm Coloured Topaz
I.8B	Standard Round Brilliant – Faceted Girdle	Coloured Cubic Zirconia
J.8B	Standard Round Brilliant – Faceted Girdle	Coloured Cubic Zirconia
O.9A	Standard Oblong Step Cut with Cut Corners	Quartz, Citrine
I.9A	Standard Oblong Step Cut with Cut Corners	Quartz, Citrine

N.9B	Standard Square Step Cut with Cut Corners	Coloured Quartz
O.10.1	Gamma Brilliant	Coloured Cubic Zirconia
O.10.2	Glass Shard Vortex	Colourless Quartz
I.10.1	Radiant Trillion (sig 4)	Colourless Topaz
I.10.2	BarRound 1	Coloured Man Made Corundum
N.10.1	99SIMP.GEM	Coloured Cubic Zirconia
N.10.2	Equilateral	Coloured Man Made Spinel
J.10.1	Opening Octagon	Colourless Topaz
O.11.1	Fortitude	Coloured Man Made Corundum
N.11.1	APHEX	Quartz, Citrine

GROUP 12: TUMBLED STONES (Special Condition A)

Minimum size - Must not be able to be passed through a 15 mm diameter circular hole

Section	Description	Material
O.12A	Tumbled Stones - Preformed Shape, Set of 3 different materials	
N.12A	Tumbled Stones – Preformed Shape, Set of 3	

GROUP 13 AND 14: POLISHED FACES

Section	Description	Material
O.13/AA	Flat Surface	Agate
N.13/AA	Flat Surface	
O.14/AA	Curved Surface	
N.14/AA	Curved Surface	

GROUP 16: GEM TREES

Base not to exceed one third of overall height (Paragraph D 16.2 of the manual still applies)

Section	Description
O.16	Gem Tree
N.16	Gem Tree
J.16	Gem Tree

GROUP 17: NOVELTY GEMCRAFT

Section	Description
O.17	Novelty Gemcraft
N.17	Novelty Gemcraft

GROUP 18: HAND-FABRICATED AND WIRE WRAPPED JEWELLERY

Section	Description
O.18A	NOT intended to include Lapidary, Fossil or Mineral Item/s
I.18A	NOT intended to include Lapidary, Fossil or Mineral Item/s
N.18A	NOT intended to include Lapidary, Fossil or Mineral Item/s
O.18B.1	WITH Lapidary Item/s cut and set by Entrant. Material – Solid Opal
O.18B.2	WITH Lapidary Item/s cut and set by Entrant. – Material – NOT Opal
I.18B	WITH Lapidary Item/s cut and set by Entrant.
N.18B	WITH Lapidary Item/s cut and set by Entrant.
O.18C	WITH Natural Fossil or Mineral Specimen/s set by Entrant
N.18C	WITH Natural Fossil or Mineral Specimen/s set by Entrant
O.18D	WITH Commercial Lapidary item/s set by Entrant
N.18D	WITH Commercial Lapidary item/s set by Entrant
O.18E	Wire-wrapped Jewellery

I.18E	WITH Lapidary, Fossil or Minerals Items prepared and set by Entrant Wire-wrapped Jewellery
N.18E	WITH Lapidary, Fossil or Minerals Items prepared and set by Entrant Wire-wrapped Jewellery
J.18E	WITH Lapidary, Fossil or Minerals Items prepared and set by Entrant Wire-wrapped Jewellery
	WITH Lapidary, Fossil or Minerals Items prepared and set by Entrant

GROUP 19: CAST JEWELLERY USING PATTERNS, MOULDS AND DIES MADE BY THE ENTRANT

Section	Description
O.19A	Cast Jewellery NOT intended to include Lapidary, Fossil or Mineral Item/s
N.19A	Cast Jewellery NOT intended to include Lapidary, Fossil or Mineral Item/s
O.19B	Cast Jewellery WITH Lapidary Item/s cut and set by Entrant
N.19B	Cast Jewellery WITH Lapidary Item/s cut and set by Entrant

GROUP 20: CAST JEWELLERY USING NATURAL OBJECTS AS PATTERNS

Section	Description
O.20A	Cast Jewellery NOT intended to include Lapidary, Fossil or Mineral Item/s
N.20A	Cast Jewellery NOT intended to include Lapidary, Fossil or Mineral Item/s

GROUP 21: CAST JEWELLERY USING COMMERCIAL WAX MODELS OR PATTERNS

Section	Description
O.21A	Cast Jewellery NOT intended to include Lapidary, Fossil or Mineral Item/s
I.21A	Cast Jewellery NOT intended to include Lapidary, Fossil or Mineral Item/s
N.21A	Cast Jewellery NOT intended to include Lapidary, Fossil or Mineral Item/s

GROUP 24: ENAMELLED JEWELLERY IN HAND FABRICATED SETTING

Section	Description
O.24A	Enamelled Jewellery in Hand-Fabricated Setting
N.24A	Enamelled Jewellery in Hand-Fabricated Setting

GROUP 25:**COMMERCIAL MOUNT JEWELLERY WITH LAPIDARY ITEM/S CUT AND SET BY ENTRANT**

Section	Description
O.25	Commercial Mount Jewellery
I.25	Commercial Mount Jewellery
N.25	Commercial Mount Jewellery
J.25	Commercial Mount Jewellery

GROUP 26: ENAMELLING SECTIONS

Section	Description
O.26A	Enamelled Jewellery in a Commercial Mount
N.26A	Enamelled Jewellery in a Commercial Mount
O.26B	Enamelled Jewellery without a Mount
N.26B	Enamelled Jewellery without a Mount
O.26C	Enamelling Non Jewellery (MUST be Functional)
N.26C	Enamelling Non Jewellery (MUST be Functional)

GROUP 27: GENERAL METALCRAFT

Section	Description
O.27A	NOT intended to include Lapidary, Fossil or Mineral Item/s

Dazlyn Gems

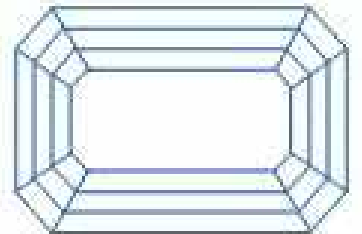

Precious & semi precious gems

Rough gems

Gem crystals

Minerals



PO Box 4196 Langwarrin, Vic 3910

Phone: (03) 9583 1998

Website: www.dazlyngems.com.au

Email: info@dazlyngems.com.au





Burfitt  Tools
AUSTRALIA

BURFITT TOOLS

Starting at \$5

Best Quality **Tools**

Burfitt tools provide high quality hand tools for use in a variety of crafts and hobbies. Murray burfitt has designed and modified some of the most useful medical instruments that have been developed over hundreds of years by surgeons. These precision tools have been adapted for use by hobbyists and modelers.

Contact Us

www.burfitt.com.au
murray@burfitt.com.au

Subscribe/Like us **for Offers**

 @burfitttools

 @burfitttoolsaustralia

Sign up to email list to get special offers.

N.27A NOT intended to include Lapidary, Fossil or Mineral Item/s

GROUP 28: SHEET METALWORK

Section Description

O.28A Bas Relief or Impressed Pattern

GROUP 29 TO 31: SHOWCASES

Section Description

O.29B General Showcase – LIT

O.31 Novelty Showcase – Any Theme

GROUP 32: FOSSILS NON-DISPLAY

Section Description

O.32A.1 Single Specimen – Vertebrate – NOT Tooth or Claw

O.32A.2 Single Specimen – Vertebrate – Tooth or Claw

N.32A Single Specimen – Any Type

J.32A Single Specimen – Any Type

Maximum plan size of whole group NOT to exceed 200 mm x 200 mm

O.32B Group of 3 – Any Type

N.32B Group of 3 – Any Type

J.32B Group of 3 – Any Type

GROUP 34: MINERALS NON-DISPLAY (Special Condition A)

Maximum size allowable for Cabinet Specimens 150 mm x 150 mm x 150 mm

Section Description

O.34A.1 Mineral Non Display, Single Specimen
Cabinet Size, Australian Specimen

O.34A.2 Mineral Non Display, Single Specimen
Miniature Size, Overseas Specimen

N.34A.1 Mineral Non Display, Single Specimen
Cabinet Size, Australian Specimen

N.34A.2 Mineral Non Display, Single Specimen
Miniature Size, Overseas Specimen

J.34A.1 Mineral Non Display, Single Specimen
Cabinet Size, Australian Specimen

J.34A.2 Mineral Non Display, Single Specimen
Miniature Size, Overseas Specimen

O.34B.1 Group of three crystal clusters, Miniatures, Australian Specimens

O.34B.2 Group of three Specimens, Each of a different species, Thumbnails

N.34B.1 Group of three crystal clusters, Miniatures

N.34B.2 Group of three Specimens, Each of a different species, Thumbnails

J.34B.1 Group of two crystal clusters, Miniatures

GROUP 37: MINERAL SHOWCASE

Section Description

O.37B Mineral Showcase – Display - Lit

GROUP 99: POPULAR CHOICE SHOWCASE (Special Condition C)

Section Description

99 Popular Choice Showcase - Lit

2020 GEMBOREE COMPETITION ENTRY FORM

Mail to: GEMBOREE Competition Manager - PO Box 500 Mooropna Vic. 3629

ENTRY FORMS for all Sections must be received by the Competition Committee by **Friday 31st January 2020**, together with a flat entry fee of \$5 per competitor and sufficient funds to cover the cost of return postage (Registered or Express Post is recommended).

*Entrants should read the complete COMPETITION SCHEDULE before entering this competition.

NAME

ADDRESS

STATE POST CODE

TELEPHONE No MOBILE No

EMAIL

NAME OF CLUB

Date of Birth (**Juniors Only**)(Under 16 on 31st January 2020)

NUMBER OF ENTRIES ENTRY FEE (\$5 Flat Rate) \$ 5.00

Will Collect Entries at Show (tick) or COST of RETURN POSTAGE \$.....

TOTAL ENCLOSED \$.....

Your Signature

“PRE-JUDGED” ENTRIES

Entries in the Sections “Pre-Judged” table must be received by the Competition Committee by Friday 31st January 2020. Please write the number of entries (1 or 2) in the spaces next to the Sections entered.

O.1A/C	I.1A/C	N.1A/C	J.1A/C	O.1A/AA	I.1A/AA	N.1A/AA	J.1A/AA
O.1B/C	I.1B/C	N.1B/C	J.1B/C	O.1B/AA	I.1B/AA	N.1B/AA	J.1B/AA
O.2A/C	I.2A/C	N.2A/C	O.2B/C	O.2B/AA	I.2B/AA	N.2B/AA	O.3/C
I.3/C	N.3/C	J.3.1/C	J.3.2/C	O.3/AA	I.3/AA	N.3/AA	O.4B/C
N.4B/C	O.7A/AA	N.7A/AA	N.8A	O.8B	I.8B	J.8B	O.9A
I.9A	N.9B	O.10.1	O.10.2	I.10.1	I.10.2	N.10.1	N.10.2
J.10.1	O.11.1	N.11.1	O.12A	N.12A	O.13/AA	N.13/AA	O.14/AA
N.14/AA	O.18A	I.18A	N.18A	O.18B.1	O.18B.2	I.18B	N.18B
O.18C	N.18C	O.18D	N.18D	O.18E	I.18E	N.18E	J.18E
O.19A	N.19A	O.19B	N.19B	O.20A	N.20A	O.21A	I.21A
N.21A	O.24A	N.24A	O.25	I.25	N.25	J.25	O.26A
N.26A	O.26B	N.26B					

“JUDGED AT SHOW” ENTRIES

Entries in the Sections below are to be delivered to the Competition Committee at the show hall between 2pm and 5pm on Thursday 9th April 2020.

Please write the number of entries (1 or 2) in the spaces next to the Sections entered.

O.5A	I.5A	N.5A	J.5A	O.5B
N.5B	O.6	N.6	O.16	N.16
J.16	O.17	N.17	O.26C	N.26C
O.27A	N.27A	O.28A	O.29B	O.31
O.32A.1	O.32A.2	N.32A	J.32A	O.32B
N.32B	J.32B	O.34A.1	O.34A.2	N.34A.1
N.34A.2	J.34A.1	J.34A.2	O.34B.1	O.34B.2
N.34B.1	N.34B.2	J.34B.1	O.37B	99

Showcase Dimensions – Please note only 1 entry per person is allowed in each Section

O.29B	O.31	O.37B	99
WIDTH	WIDTH	WIDTH	WIDTH
DEPTH	DEPTH	DEPTH	DEPTH
HEIGHT	HEIGHT	HEIGHT	HEIGHT

Are you looking at your club's copy?

A friend's copy?

No more booklets in your club?

Download the booklet.

Download the competition schedule.

ALFLACA <https://aflaca.org.au/>

VGCA <http://www.victoriangemclubsassociationinc.com/>

Or

Email vgca1lapidary@gmail.com

PERPETUAL TROPHIES and CONDITIONS

PT01 Tom Jenkins.

Open Champion Lapidary

Donor: Victorian Gem Clubs' Association

Highest aggregate score of entrant's best entry in each of the following 5 Open Sections:

- O.1A/C Standard Cabochon
- O.1B/C Fancy Cabochon
- O.2B/C Double Fancy Cabochon
- O.4B/C Opal Doublet
- O 8B Standard Round Brilliant – Faceted Girdle (8mm) Coloured Topaz

PT02 Harold Evans.

Intermediate Champion Lapidary

Donor: Victorian Gem Clubs' Association Inc.

Highest aggregate score of entrant's best entry in any 3 of the following 4 Intermediate Sections:

- I.1A/C Standard Cabochon
- I.1B/C Fancy Cabochon
- I.9A Standard Square Step Cut with Cut Corners – Quartz, Citrine
- I.25 Commercial Mount Jewellery with Lapidary Item/s Cut & Set by Entrant.

PT-03 Norm Patison .

Novice Champion Lapidary

Donor: P. Murphy & T. Annear via AFLACA Trophy Fund.

Highest aggregate score of entrant's best entry in each of any 4 of the following 5 Novice Sections:

- N.1A/C Standard Cabochon
- N.1B/C Fancy Cabochon
- N.2A/C Double Fancy Cabochon
- N.9B Standard Square Step Cut with Cut Corners. Coloured Quartz
- N.25 Commercial Mount Jewellery with Lapidary Item/s Cut & Set by Entrant

PT-04 Ray Powell.

Champion Club

Donor: Gem & Lapidary Council of NSW Inc.

Club with highest aggregate members' points based on the following:

- 20 points for highest scoring entry/entries in each Section (Special Award = First Place)
- 15 points for the 2nd highest scoring entry/entries in each Section
- 10 points for the 3rd highest scoring entry/entries in each Section
- 5 points for the 4th highest scoring entry/entries in each Section

ANNUAL TROPHIES

AT-01 Dorothy Caladine.

Junior Champion Lapidary

Donor: Mrs. Rhonda Sabella.

Highest aggregate score of entrant's best entry in each of any 3 of the following 5 Junior Sections:

- J.1A/C Standard Cabochon
- J.1B/C Fancy Cabochon
- J.3.1/C Free Form
- J.3.2/C Free Form - solid opal - minimum size 10mm
- J.25 Commercial Mount Jewellery with Lapidary Item/s Cut & Set by Entrant

AT-02 Far Out Crystals, Gems & Minerals.

Open - Hand Fabricated Jewellery

Donor: Far Out Crystals Gems & Minerals

Entrant with highest scoring entry in section

- O.18A Hand Fabricated Jewellery. Not Intended to Include Lapidary, Fossil or Mineral items.

AT-03 Dorothy Caladine.

Junior Carving

Donor: Mrs. Rhonda Sabella

Entrant with highest scoring entry in Section

- J.5A Carving - Fully 3-Dimensional 'Known Form' 'Any Hardness'

AT-04 The Crystal Habit Trophy.

-Best Mineral of the Show

Donor: Peter Beckwith

Donor selects winning entry from all minerals on display, whether in competition or not. Display specimens belonging to Dealers or Institutions are NOT eligible for this award.

AT-05 Val Annear.

Open - Enamelling - Non-Jewellery

Donor: Victorian Gem Clubs Association Inc. In memory of Tony Annear

Entrant with highest scoring entry in Section

- O.26C Enamelling Non-Jewellery – Must be Functional

AT-06 John S. Ryding.

Open - Hand Made Jewellery with Natural Fossil or Mineral Specimen/s

Donor: Mrs. J. Ryding via AFLACA Trophy Fund.

Entrant with highest scoring entry in:

- Section O.18C Hand Made Jewellery with Natural Fossil or Mineral Specimen/s Set by Entrant

AT-07 Harry Miller.

Open - Standard Cabochon/AA

Donor: Mrs. D. Miller via AFLACA Trophy Fund.

Entrant with highest scoring entry in Section
O.1A/AA Standard Cabochon

AT-08 Earth Stones.

Best Fossil of the Show

Donor: Mr. Jon Mommers

Donor selects winning entry from all fossils on display, whether in competition or not. Display specimens belonging to Dealers or Institutions are NOT eligible for this award.

AT-09 George Lude.

Open - 3 Australian Crystal Clusters

Donor: Queensland Lapidary & Allied Craft Clubs' Association, Inc.

Entrant with highest scoring entry in Section
O.34B.1 Group of 3 Australian Crystal Clusters
– Miniature Size

AT-10 Alex Amess.

Open - Facet Cut

Donor: Victorian Gem Clubs' Association Inc.

Entrant with highest scoring entry in Section
O.10.2 Glass Shard Vortex - Colourless
Quartz.

AT-11 A & E Metal Merchants.

Open - Hand Made Jewellery with Lapidary
Item/s Cut and Set by Entrant

Donor: A & E Metal Merchants

Entrant with highest scoring entry in Section
O.18B.2 Hand Made Jewellery with
Lapidary Item/s Cut and Set by
Entrant – NOT OPAL.

AT-12 Jim Johnson.

Novice - Champion Mineral Entrant

Donor: Gem & Mineral Clubs' Association of SA Inc. and others via AFLACA Trophy Fund.

Entrant with the highest aggregate score of their best entry in each of a minimum of any 3 of the Novice Mineral Sections - including Showcase.

AT-13 Broken Hill Centenary.

Open - Champion Mineral Entrant

Donor: Arthur Roffey

Entrant with the highest aggregate score of their best entry in each of a minimum of 3 Open Mineral Sections.

AT-14 Ted Koller.

Open - Solid Opal Cut

Donor: Victorian Gem Clubs' Association Inc.

Entrant with highest scoring entry in Section
O.3/C Free Form – Solid Opal

AT-15 Dazlyn Gems.

Junior - Standard Cabochon/C

Donor: Dazlyn Gems

Entrant with highest scoring entry in Section J.1A/C
Standard Cabochon.

AT-16 Peter Collins.

Open - Champion Facetor

Donor: Australian Facetors' Guild Ltd.

Entrant with the highest aggregate score of their best entry in each of the following 3 Open Faceting Sections:

- | | |
|--------|--|
| O.9A | Standard Oblong Step Cut with Cut
Corners – Quartz, Citrine |
| O.10.1 | Gamma Brilliant – Coloured Cubic
Zirconia |
| O.11.1 | Fortitude – Coloured Man Made
Corundum |

If tied, the Entrant with the highest points scoring entry will be the winner.

AT-17 Arthur Roffey.

Open - Showcase General – Lit

Donor: Arthur Roffey

Entrant with highest scoring entry in Section
O.29B Showcase General – Lit

AT-18 Boris Novic.

Open - Double Standard Cabochon/C

Donor: Gem & Lapidary Council of NSW Inc.

Entrant with highest scoring entry in Section
O.2A/C Double Standard Cabochon –
Coloured, Transparent Quartz.

AT-19 Patrick C Murphy.

Junior - Champion Mineral Entrant

Donor: Arthur Roffey

Junior entrant's highest aggregate score of their best entries in each of a minimum of 3 Mineral Sections, irrespective of Division - including Showcase.

AT-20 Cyril Kovac.

Open - Mineral Showcase – Display – Lit

Donor: Cyril Kovac of C K Minerals

Entrant with highest scoring entry in Section
O.37B Mineral Showcase – Display – Lit.

AT-21 Brian Bown.

Open - Standard Cabochon/C

Donor: Brian Bown

Entrant with highest scoring entry in Section
O.1A/C Standard Cabochon – Agate.

AT-22 Jack Bushby.

Novice Champion Facetor

Donor: Southern Rockhounds

Entrant with the highest aggregate score of their best entry in each of the following 3 Novice Faceting

Sections:

- N.9B Standard Square Step Cut with
Cut Corners – Coloured Quartz
- N.10.1 99Simp.GEM – Coloured Cubic
Zirconia
- N.10.2 Equilateral – Coloured Man Made
Corundum

If tied, the Entrant with the highest points scoring entry will be the winner.

AT-23 Dick Moppett.

Open - Standard Facet Cuts

Donor: Gem & Lapidary Council of NSW Inc.

Entrant with the highest aggregate score of their best entry in each of the following 2 Open

Faceting Sections:

- O.8B Standard Round Brilliant - Faceted
Girdle – 8mm – Coloured Topaz

- O.9A Standard Oblong Step Cut with
Cut Corners – Quartz, Citrine

Both cut from Specified Natural Australian Material.

AT-24 Chas Totterdell.

Open - Hand Made Jewellery with Opal

Donor: Gem & Lapidary Council of NSW Inc.

Entrant with highest scoring entry in Section

- O.18B.1 Hand Fabricated Jewellery with
Item/s Cut and Set by Entrant –
SOLID OPAL.

AT-25 The Lapidary & Gem Clubs of Victoria.

Open – Carving

Donor: AFLACA Trophy Fund

Entrant with highest scoring entry in Section

- O.5A Fully 3-Dimensional – Any
Hardness.

AT-26 Gold Coast School of Wirecraft.

Wire Wrapped Jewellery

Donor: Sir Paul Howard

Entrant with the highest scoring entry in Section

- N.18E Wire Wrapped Jewellery with
Lapidary, Fossil or Mineral Item/s
Prepared and Set by Entrant.

AT-27 The Tony Annear OAM Memorial Trophy

Donor: AFLACA Trophy Fund

Highest aggregate score of the Entrant's best entry in the Groups listed below.

(Regardless of Divisions entered and the number of Groups entered)

- Group 1 Fancy Cabochon
Group 3 Free Form
Group 5 Carving

- Group 10 Faceting – (Modified Standard Cuts)
Group 11 Faceting – (Fancy Cuts)
Group 12 Tumbled Stones
Group 13 Polished Faces – (Flat Face)
Group 17 Novelty Gemcraft
Group 18 Hand Fabricated Jewellery
Group 34 Minerals.

AT-28 Queensland Gem Clubs Association.

Cast Jewellery.

Donor: Queensland Gem Clubs' Association Inc.

Highest individual scoring entry in any of the Cast Jewellery Sections:

(Regardless of Division/s Entered)

Cast Jewellery - Section 19A & 19B

Cast Jewellery - Section 20A

Cast Jewellery - Section 21A

AT-29 Champion Intermediate Facetor.

Donor: Australian Facetors' Guild

Highest aggregate score of Entrant's best entry in any three INTERMEDIATE Faceting Sections, as specified in the schedule

If tied, Entrant with the highest points scoring entry will be the winner

- I.8B Standard Round Brilliant – Faceted
Girdle – Coloured Cubic Zirconia

- I.10.1 Radiant Trillion (sig4) – Colourless
Topaz

- I.10.2 BarRound 1 – Coloured Man Made
Corundum

SPECIAL TROPHIES and CONDITIONS:

ST-01 Senior Princess

Donor: Victorian Gem Clubs' Association

GEMBOREE Senior Princess is chosen and crowned by GEMBOREE organisers.

ST-02 Junior Princess

Donor: Tasmanian Lapidary Association

GEMBOREE Junior Princess is chosen and crowned by GEMBOREE organisers.

ST-03 Best Presented Trade Stand.

BEST PRESENTED TRADE STAND

Donor: Shepparton & District Gem Club Inc.

Awarded to the Commercial Dealer whose stand is judged 'Best Presented' by someone appointed by the Donor or the GEMBOREE Committee.

NOVICE SECTION N.8A

Material:
Facets: 58

Colourless Topaz
Meets: 41 (crown: 24, pavilion: 17)

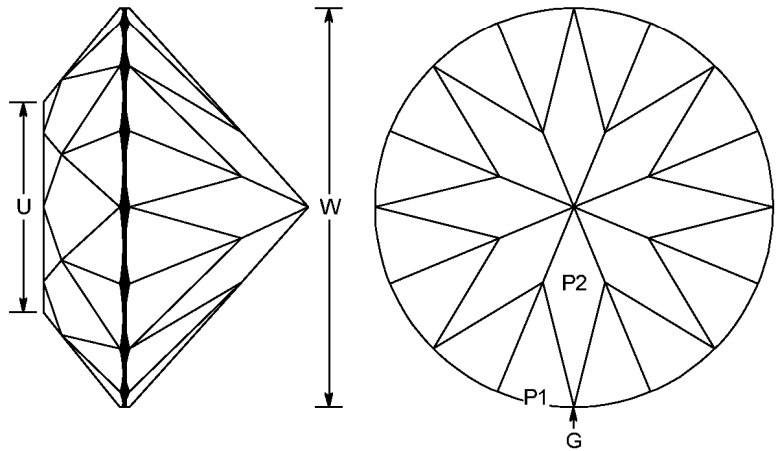
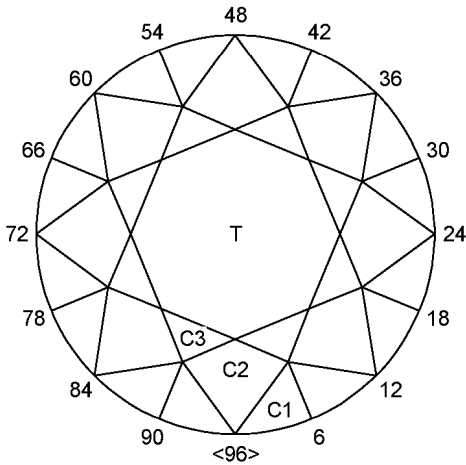

Standard Brilliant - Continuous Girdle

Computer Work by Rick Parker, for GEMBOREE 2020.

Angles for R.I. = 1.610

57 + 1 girdle = 58 facets

8-fold, mirror-image symmetry

96 index

L/W = 1.000 T/W = 0.525 U/W = 0.525

P/W = 0.459 C/W = 0.202

Vol./W³ = 0.229

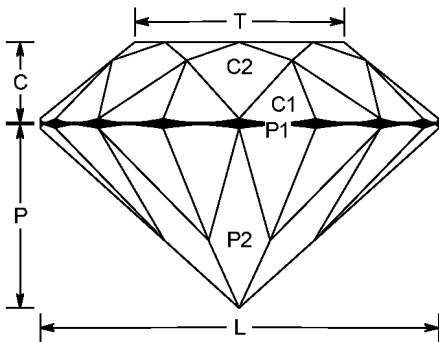

PAVILION

P1	44.00°	03-09-15-21-27-33-39-45- 51-57-63-69-75-81-87-93	TCP
G	90.00°		cut to size 'rolled girdle'
P2	42.00°	96-12-24-36-48-60-72-84	meet P1-P1 at girdle, PCP

CROWN

C1	44.00°	03-09-15-21-27-33-39-45- 51-57-63-69-75-81-87-93	set girdle width
C2	39.00°	96-12-24-36-48-60-72-84	meet C1-C1 at girdle
C3	24.00°	06-18-30-42-54-66-78-90	meet C2-C2-C1-C1
T	0.00°	Table	meet C3-C3-C2

OPEN SECTION O.8B

Material: Coloured Topaz
 Specified Size: 8mm
 Facets: 73 Meets: 57 (crown: 32, pavilion: 25)

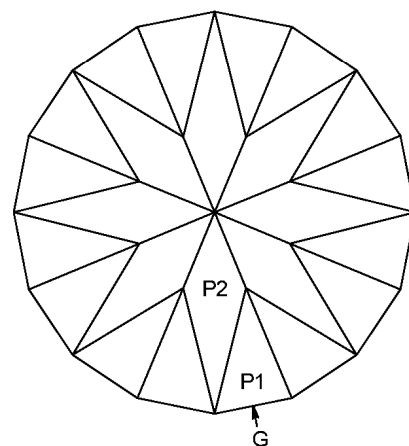
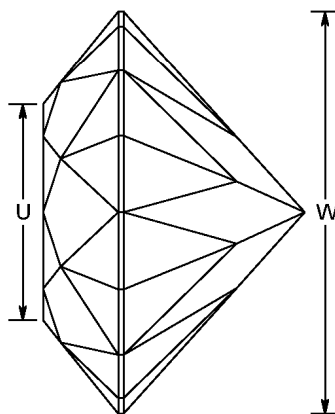
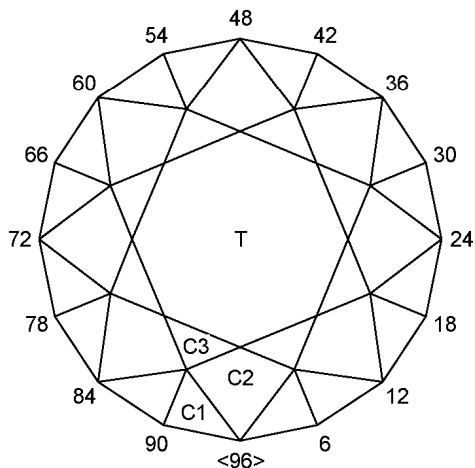

Standard Brilliant - Faceted Girdle

Computer Work by Rick Parker, for GEMBOREE 2020.

Angles for R.I. = 1.610

57 + 16 girdles = 73 facets

8-fold, mirror-image symmetry

96 index

$L/W = 1.000$ $T/W = 0.537$ $U/W = 0.537$

$P/W = 0.450$ $C/W = 0.188$

$Vol./W^3 = 0.219$

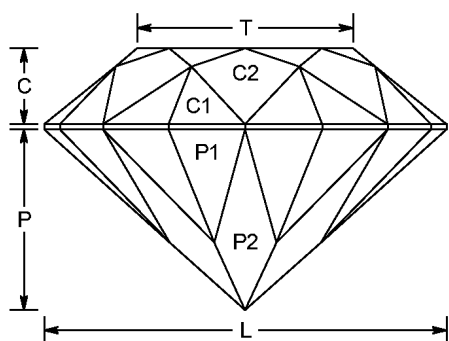

PAVILION

P1	44.00°	03-09-15-21-27-33-39-45-51-57-63-69-75-81-87-93	TCP
G	90.00°	03-09-15-21-27-33-39-45-51-57-63-69-75-81-87-93	set stone size
P2	42.00°	96-12-24-36-48-60-72-84	meet P1 P1 at girdle, PCP

CROWN

C1	44.20°	03-09-15-21-27-33-39-45-51-57-63-69-75-81-87-93	set girdle width
C2	39.00°	96-12-24-36-48-60-72-84	meet C1 C1 at girdle
C3	23.60°	06-18-30-42-54-66-78-90	meet C1 C1 C2 C2
T	0.00°	Table	meet C2 C3 C3

INTERMEDIATE / JUNIOR SECTIONS I.8.B & J.8.B

Material:

Coloured CZ

Facets: 73

Meets: 57 (crown: 32, pavilion: 25)

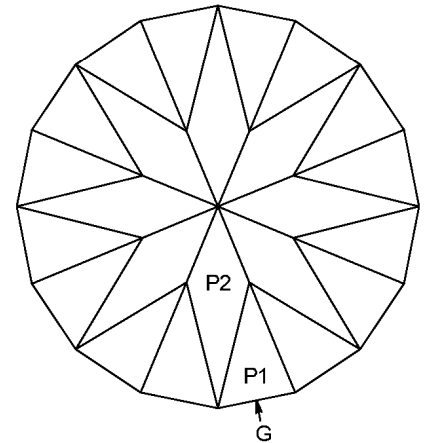
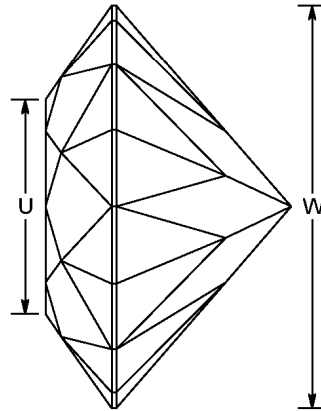
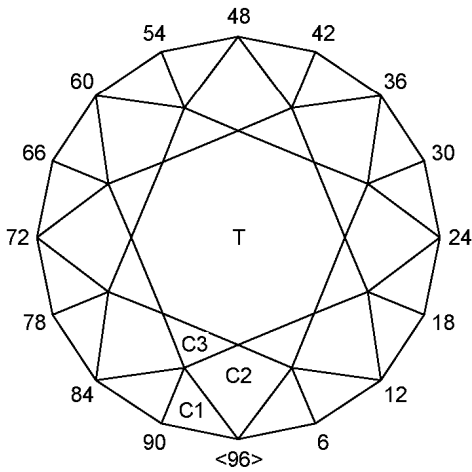

Standard Brilliant - Faceted Girdle

Computer Work by Rick Parker, for GEMBOREE 2020.

Angles for R.I. = 2.160

57 + 16 girdles = 73 facets

8-fold, mirror-image symmetry

96 index

$L/W = 1.000$ $T/W = 0.531$ $U/W = 0.531$

$P/W = 0.435$ $C/W = 0.164$

$Vol./W^3 = 0.203$

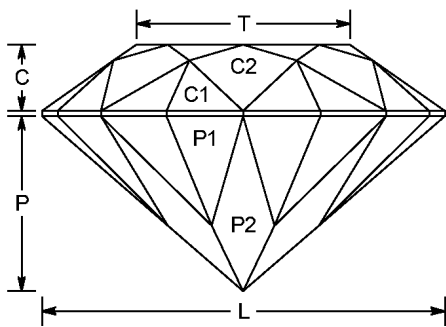

PAVILION

P1	43.00°	03-09-15-21-27-33-39-45-51-57-63-69-75-81-87-93	TCP
G	90.00°	03-09-15-21-27-33-39-45-51-57-63-69-75-81-87-93	set stone size
P2	41.00°	96-12-24-36-48-60-72-84	meet P1 P1 at girdle, PCP

CROWN

C1	40.00°	03-09-15-21-27-33-39-45-51-57-63-69-75-81-87-93	set girdle width
C2	35.00°	96-12-24-36-48-60-72-84	meet C1 C1 at girdle
C3	21.00°	06-18-30-42-54-66-78-90	meet C1 C1 C2 C2
T	0.00°	Table	meet C2 C3 C3

OPEN / INTERMEDIATE SECTIONS O.9A & I.9A

Material: Natural Citrine
 Facets: 53 Meets: 44 (crown: 24, pavilion: 20)

60 48 36

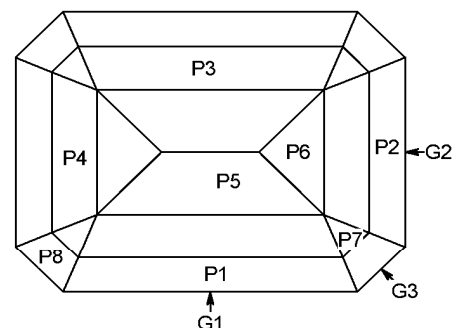
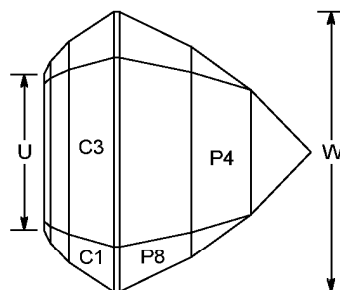
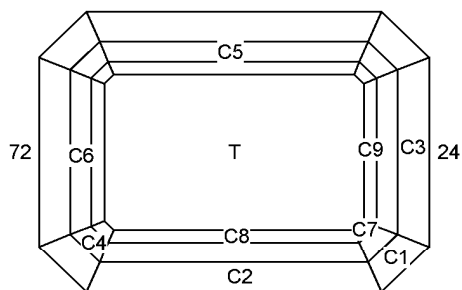

84 <96> 12

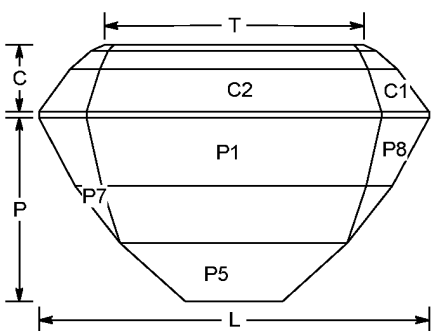

Standard Oblong Step Cut with Cut Corners

Computer Work by Rick Parker, for GEMBOREE 2020.

Angles for R.I. = 1.540

45 + 8 girdles = 53 facets

2-fold, mirror-image symmetry

96 index

$L/W = 1.333$ $T/W = 0.887$ $U/W = 0.554$

$P/W = 0.655$ $C/W = 0.239$

$Vol./W^3 = 0.643$

PAVILION

G1	90.00°	96-48	set width
G2	90.00°	24-72	set length, Note 1
P1	63.00°	96-48	cut as required, size by eye, form girdle
P2	63.00°	24-72	level girdle
P3	53.00°	96-48	cut as required, size by eye
P4	53.00°	24-72	meet P1 P2 P3
P5	43.00°	96-48	cut as required, size by eye, form keel
P6	43.00°	24-72	meet P3 P4 P5
P7	53.00°	12-36-60-84	meet P3 P4 P5 P6
P8	63.00°	12-36-60-84	meet P1 P3 P7
G3	90.00°	12-36-60-84	level girdle

CROWN

C1	55.00°	12-36-60-84	set girdle width
C2	55.00°	96-48	level girdle
C3	55.00°	24-72	level girdle
C4	42.00°	12-36-60-84	cut as required, size by eye
C5	42.00°	96-48	meet C1 C2 C4
C6	42.00°	24-72	meet C1 C3 C4
C7	26.00°	12-36-60-84	cut as required, size by eye
C8	26.00°	96-48	meet C4 C5 C7
C9	26.00°	24-72	meet C4 C6 C7
T	0.00°	Table	cut as required, size by eye

Most of the proportions of this stone are achieved by cutting facets 'cut as required, size by eye' NOT by using a meetpoint sequence.

Note 1. Ensure 'L' to 'W' ratio provides an oblong with a definite 'keel'.

NOVICE SECTION N.9B

Material:

Coloured Natural Quartz

Facets: 53

Meets: 45 (crown: 24, pavilion: 21)

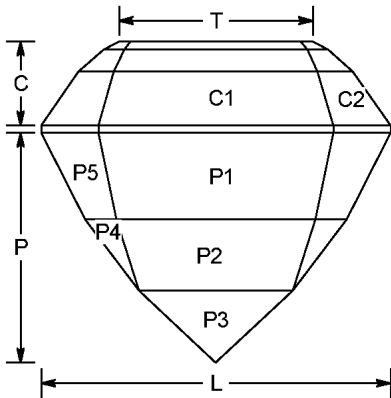
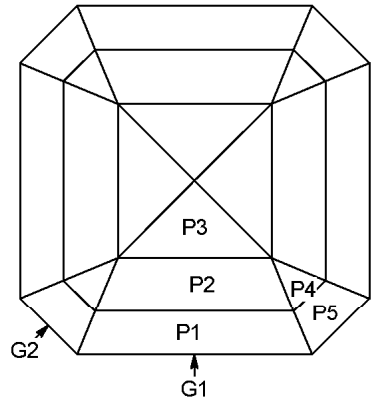
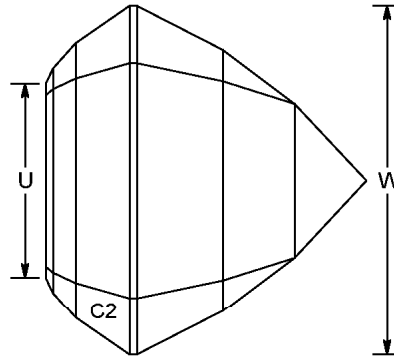
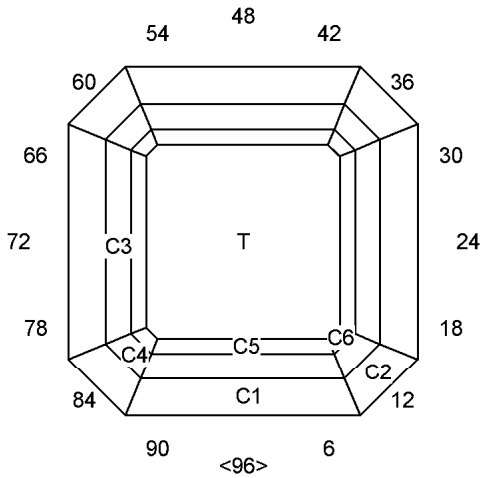

Standard Square Step Cut with Cut Corners

Computer Work by Rick Parker, for GEMBOREE 2020.

Angles for R.I. = 1.540

45 + 8 girdles = 53 facets

4-fold, mirror-image symmetry

96 index

L/W = 1.000 T/W = 0.554 U/W = 0.554

P/W = 0.656 C/W = 0.240

Vol./W³ = 0.444

PAVILION

P1	63.00°	96-24-48-72	TCP
G1	90.00°	96-24-48-72	set size
P2	53.00°	96-24-48-72	cut as required, size by eye, TCP
P3	43.00°	96-24-48-72	cut as required, size by eye, PCP
P4	53.00°	12-36-60-84	meet P2-P2-P3-P3
P5	63.00°	12-36-60-84	meet P1-P2-P4
G2	90.00°	12-36-60-84	level girdle

CROWN

C1	55.00°	96-24-48-72	set girdle width
C2	55.00°	12-36-60-84	level girdle
C3	42.00°	96-24-48-72	cut as required, size by eye
C4	42.00°	12-36-60-84	meet C1-C2-C3
C5	26.00°	96-24-48-72	cut as required, size by eye
C6	26.00°	12-36-60-84	meet C3-C4-C5
T	0.00°	Table	cut as required, size by eye

Most of the proportions of this stone are achieved by cutting facets 'cut as required, size by eye' NOT by using a meetpoint sequence.

OPEN SECTION O.10.1

Material:

Coloured CZ

Facets: 97

Meets: 65 (crown: 32, pavilion: 33)

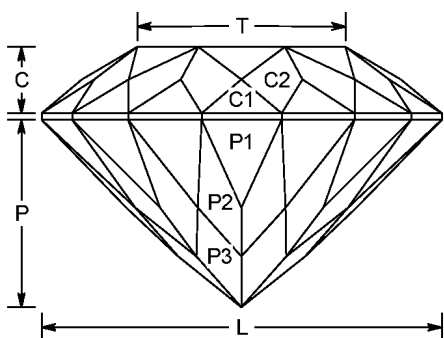
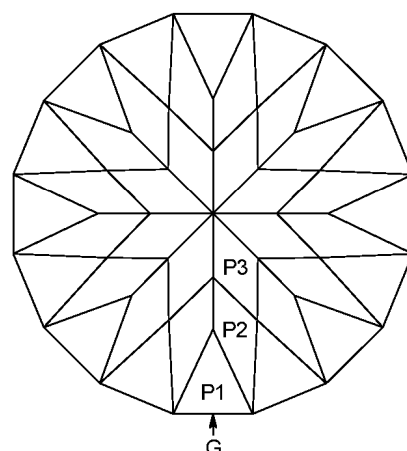
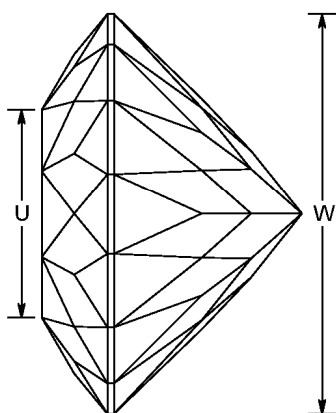
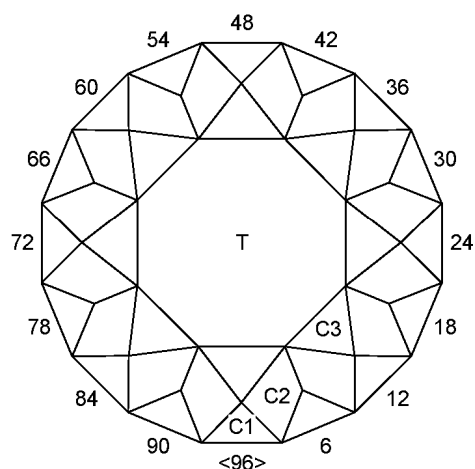

Gamma Brilliant

2008 USFG Single Stone Competition

Computer Work by Rick Parker, for GEMBOREE 2020.

Angles for R.I. = 2.160

81 + 16 girdles = 97 facets

8-fold, mirror-image symmetry

96 index

$L/W = 1.000$ $T/W = 0.521$ $U/W = 0.521$

$P/W = 0.469$ $C/W = 0.166$

$Vol./W^3 = 0.228$

PAVILION

P1	46.00°	96-06-12-18-24-30-36-42-48-54-60-66-72-78-84-90	TCP
G	90.00°	96-06-12-18-24-30-36-42-48-54-60-66-72-78-84-90	set stone size
P2	44.00°	03-09-15-21-27-33-39-45-51-57-63-69-75-81-87-93	meet P1 P1 G, TCP
P3	40.90°	06-18-30-42-54-66-78-90	meet P1 P2 P2, PCP

CROWN

C1	39.80°	96-06-12-18-24-30-36-42-48-54-60-66-72-78-84-90	set girdle width
C2	35.40°	03-09-15-21-27-33-39-45-51-57-63-69-75-81-87-93	meet C1 C1 G
C3	30.50°	96-12-24-36-48-60-72-84	meet C1 C2 C2
T	0.00°	Table	meet C2 C2 C3 C3

OPEN SECTION O.10.2

Material:

Colourless Natural Quartz

Facets: 67

Meets: 49 (crown: 30, pavilion: 19)

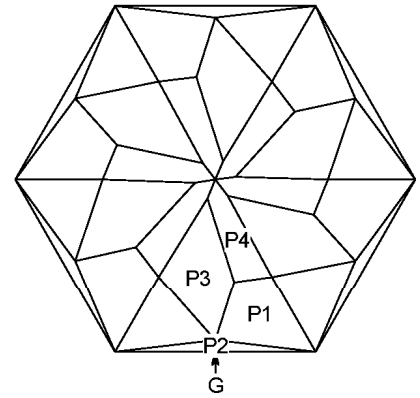
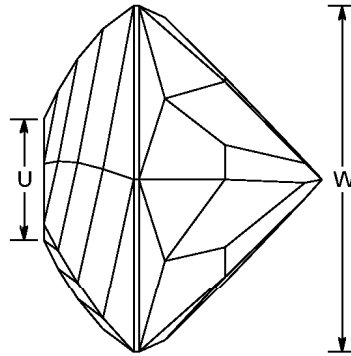
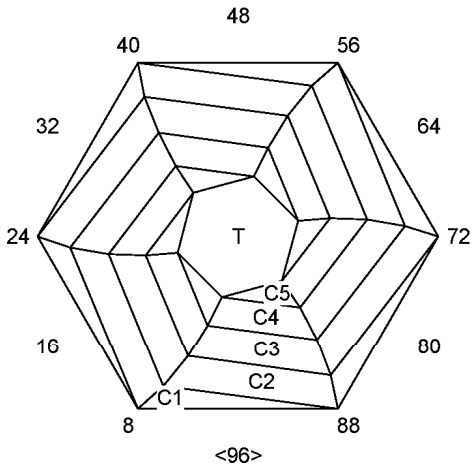

Glass Shard Vortex

by Arya Akhavan (November 2012)

Computer Work by Rick Parker, for GEMBOREE 2020.

Angles for R.I. = 1.540

61 + 6 girdles = 67 facets

6-fold radial symmetry

96 index

$L/W = 1.155$ $T/W = 0.348$ $U/W = 0.348$

$P/W = 0.527$ $C/W = 0.259$

$Vol./W^3 = 0.306$

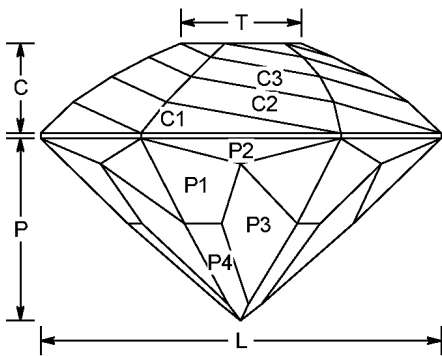

PAVILION

P1	46.60°	02-14-18-30-34-46-50-62-66-78-82-94	TCP
G	90.00°	96-16-32-48-64-80	set stone size
P2	66.20°	96-16-32-48-64-80	level girdle
P3	44.60°	01-17-33-49-65-81	meet P1 P1 P2, TCP
P4	43.00°	14-30-46-62-78-94	meet P1 P1 P3, PCP

CROWN

C1	53.40°	96-16-32-48-64-80	set girdle width
C2	42.00°	15-31-47-63-79-95	meet C1 C1 G G
C3	34.20°	14-30-46-62-78-94	meet C1 C2 C2
C4	28.70°	13-29-45-61-77-93	meet C2 C3 C3
C5	24.70°	12-28-44-60-76-92	meet C3 C4 C4
T	0.00°	Table	meet C4 C5 C5

Spiral will rotate in the opposite direction if your index gear is not the same rotational direction as a Halls Faceting Machine.

'Entries' with a counter-rotating spiral will be 'Eligible'.

INTERMEDIATE SECTION I.10.1

Material:
Facets: 55

Colourless Topaz
Meets: 37 (crown: 21, pavilion: 16)

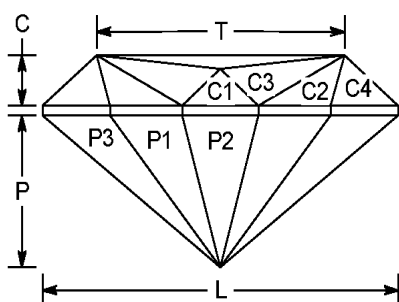
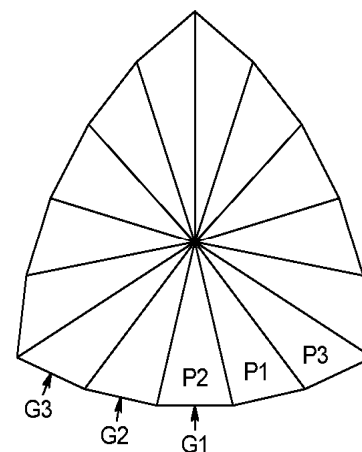
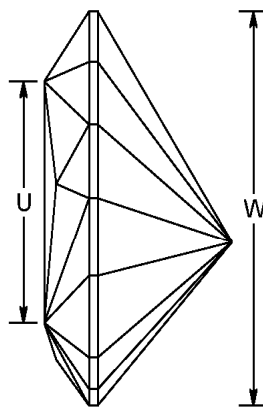
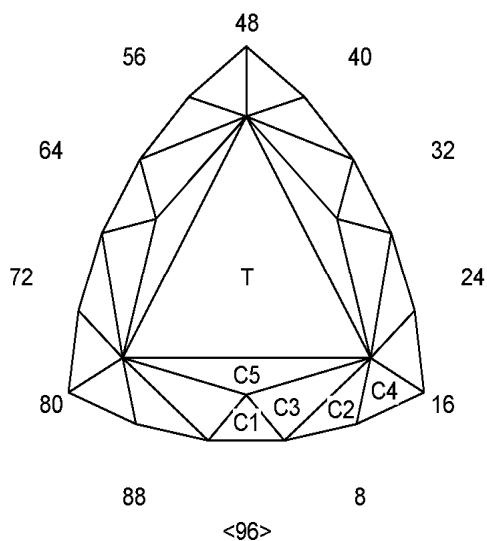

Signature #4 (Radiant Trillion)

by Jeff R. Graham. 2000.

Computer Work by Rick Parker, for GEMBOREE 2020.

Angles for R.I. = 1.610

40 + 15 girdles = 55 facets

3-fold, mirror-image symmetry

96 index

$L/W = 1.015$ $T/W = 0.708$ $U/W = 0.613$

$P/W = 0.385$ $C/W = 0.128$

$Vol./W^3 = 0.166$

PAVILION

P1	42.00°	03-29-35-61-67-93	PCP
P2	42.90°	96-32-64	PCP
P3	39.60°	06-26-38-58-70-90	PCP
G1	90.00°	96-32-64	cut to size
G2	90.00°	03-29-35-61-67-93	meet P1 P2 G1, level girdle
G3	90.00°	06-26-38-58-70-90	meet P1 P3 G2, level girdle

CROWN

C1	39.00°	96-32-64	set girdle width
C2	39.00°	03-29-35-61-67-93	meet C1 G1 G2
C3	36.00°	02-30-34-62-66-94	meet C1 C2 G1 G2
C4	42.23°	06-26-38-58-70-90	meet C2 G2 G3, C2 C2 C3 C3, Note 1
C5	20.01°	96-32-64	meet C1 C3 C3, C2 C2 C3 C3 C4 C4, Note 1
T	0.00°	Table	meet C2 C3 C4 C5

Note 1: Cheat angle to achieve both meet points.

INTERMEDIATE SECTION I.10.2

Material:

Coloured MM Corundum

Facets: 53

Meets: 45 (crown: 28, pavilion: 17)

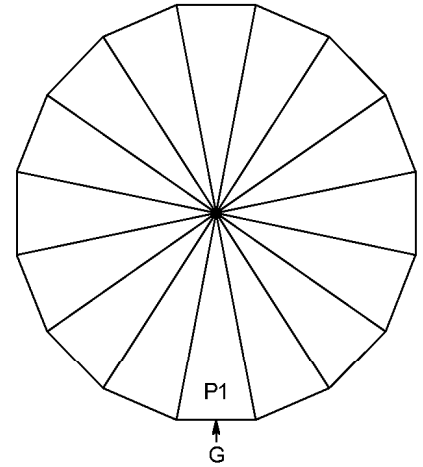
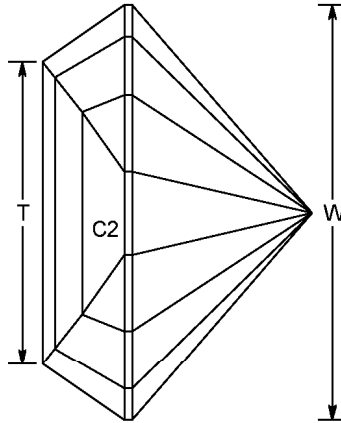
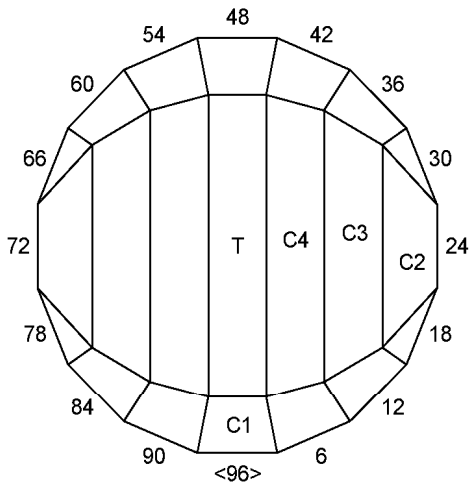

BarRound1 by Bob Keller

2004 USFG SSC Novice Stone

Computer work by Rick Parker, GEMBOREE 2020.

Angles for R.I. = 1.760

37 + 16 girdles = 53 facets

2-fold, mirror-image symmetry

96 index

L/W = 1.000 T/W = 0.727 U/W = 0.145

P/W = 0.450 C/W = 0.205

Vol./W³ = 0.242

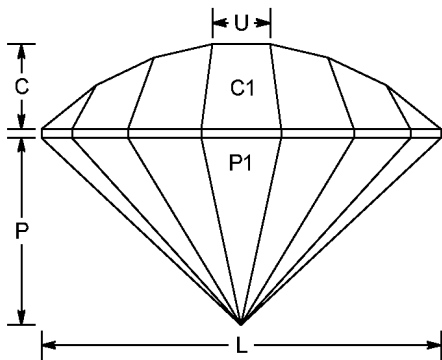

PAVILION

P1 42.00° 96-06-12-18- PCP
24-30-36-42-
48-54-60-66-
72-78-84-90

G 90.00° 96-06-12-18- set stone size
24-30-36-42-
48-54-60-66-
72-78-84-90

CROWN

C1 56.40° 96-06-12-18- set girdle width, Note 1
30-36-42-48-
54-60-66-78-
84-90

C2 38.00° 24-72 meet C1 G, Note 1

C3 24.80° 24-72 meet C1 C1 C2

C4 12.20° 24-72 meet C1 C1 C3

T 0.00° Table meet C1 C1 C4

Note 1: Girdle created by C1 & C2.

NOVICE SECTION N.10.1

Material:

Coloured CZ

Facets: 25

Meets: 19 (crown: 12, pavilion: 7)

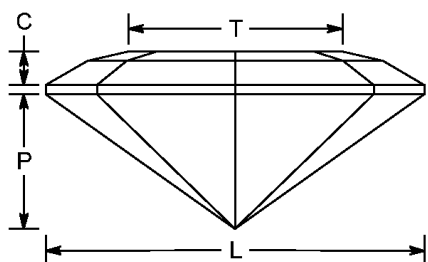
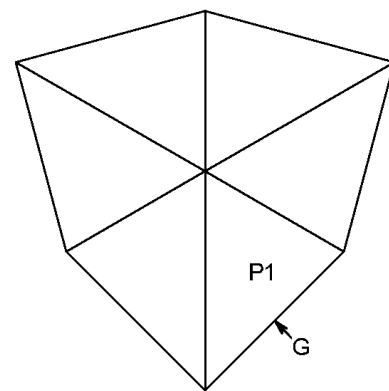
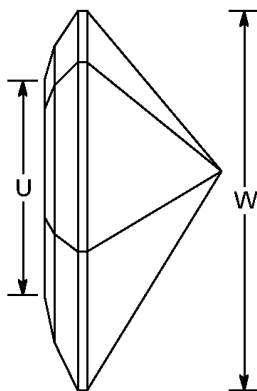
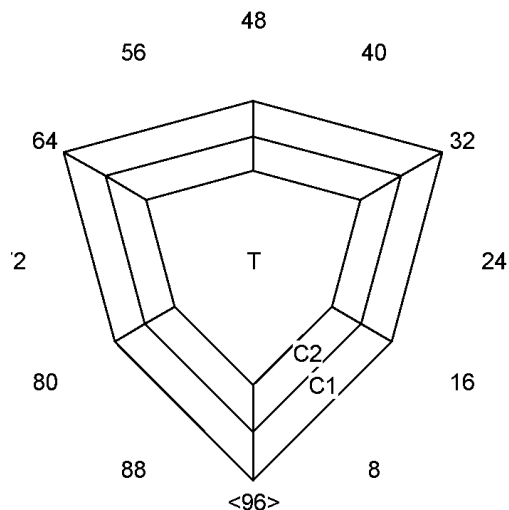

99SIMP

UKFCG Annual Competition 1999

Computer Work by Rick Parker, for GEMBOREE 2020.

Angles for R.I. = 2.160

19 + 6 girdles = 25 facets

3-fold, mirror-image symmetry

96 index

$L/W = 1.000$ $T/W = 0.566$ $U/W = 0.566$

$P/W = 0.355$ $C/W = 0.088$

$Vol./W^3 = 0.130$

PAVILION

P1 41.00° 12-20-44-52-76-84 PCP

G 90.00° 12-20-44-52-76-84 set stone size

CROWN

C1 35.00° 12-20-44-52-76-84 set girdle width

C2 16.00° 12-20-44-52-76-84 cut as required, size by eye

T 0.00° Table cut as required, size by eye

NOVICE SECTION N.10.2

Material:

Coloured MM Spinel

Facets: 34

Meets: 19 (crown: 12, pavilion: 7)

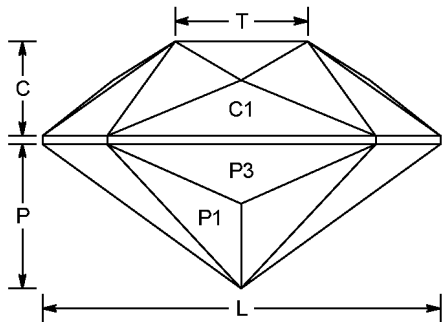
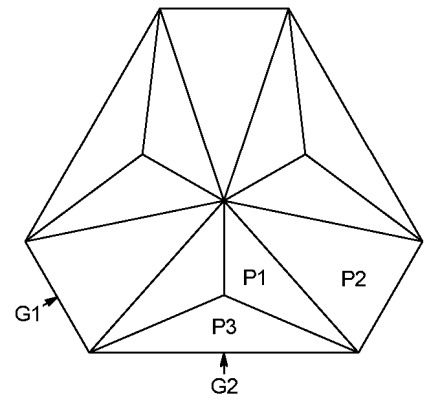
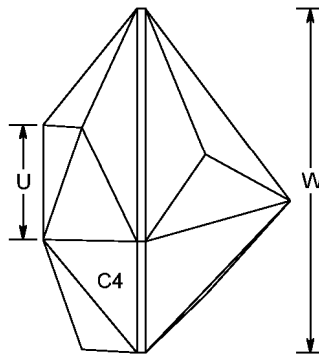
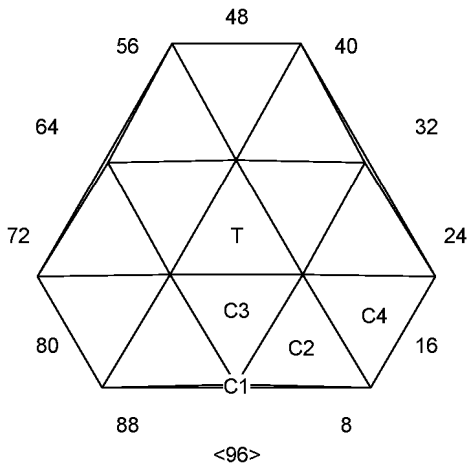

Equilateral

by Greg Glenn.

Computer Work by Rick Parker, GEMBOREE 2020.

Angles for R.I. = 1.720

28 + 6 girdles = 34 facets

3-fold, mirror-image symmetry

96 index

$L/W = 1.155$ $T/W = 0.386$ $U/W = 0.335$

$P/W = 0.419$ $C/W = 0.273$

$Vol./W^3 = 0.273$

PAVILION

P1	42.00°	01-31-33-63-65-95	PCP
P2	36.90°	16-48-80	PCP
G1	90.00°	16-48-80	set stone size
G2	90.00°	96-32-64	meet P1 P2 G1, girdle will not be level
P3	46.00°	96-32-64	meet P1 P2 G1 G2, level girdle

CROWN

C1	86.30°	96-32-64	set girdle width
C2	35.40°	09-23-41-55-73-87	meet C1 G1 G2
C3	19.40°	96-32-64	meet C1 C2 C2
C4	39.09°	16-48-80	meet C1 C2 G1 G2, C2 C2 C3 C3, Note 1
T	0.00°	Table	meet C2 C2 C3 C3 C4

Note 1: Cheat angle to achieve all meet points.

JUNIOR SECTION J.10.1

Material:
Facets: 25

Colourless Topaz
Meets: 17 (crown: 8, pavilion: 9)

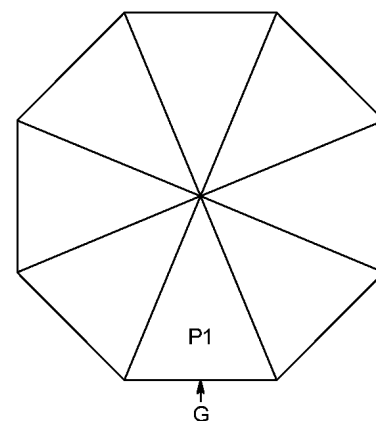
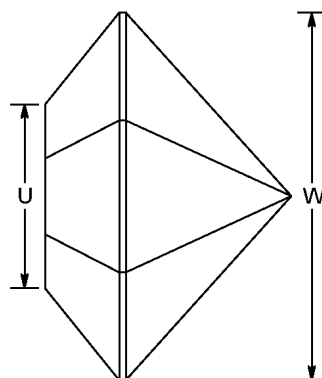
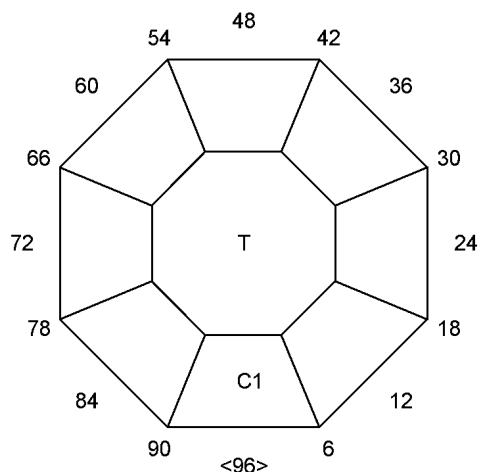

Opening Octagon

by Arya Akhavan (October 2012)

Computer Work by Rick Parker, for GEMBOREE 2020.

Angles for R.I. = 1.610

17 + 8 girdles = 25 facets

8-fold, mirror-image symmetry

96 index

$L/W = 1.000$ $T/W = 0.500$ $U/W = 0.500$

$P/W = 0.450$ $C/W = 0.202$

$Vol./W^3 = 0.238$

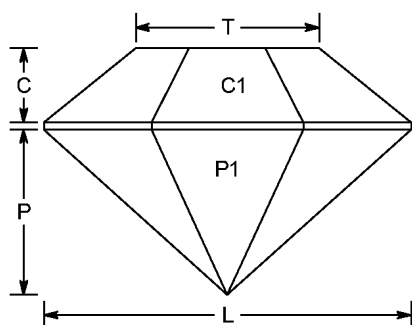

PAVILION

P1 42.00° 96-12-24-36-48-60-72-84 PCP

G 90.00° 96-12-24-36-48-60-72-84 set stone size

CROWN

C1 39.00° 96-12-24-36-48-60-72-84 set girdle width

T 0.00° Table cut to 50% of stone width

OPEN SECTION O.11.1

Material:
Facets: 80

Coloured MM Corundum
Meets: 66 (crown: 37, pavilion: 29)

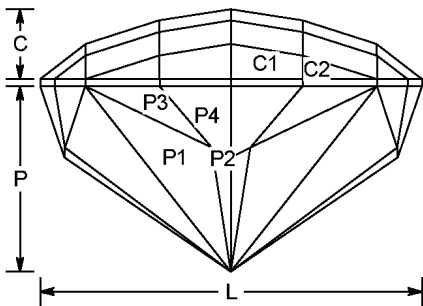
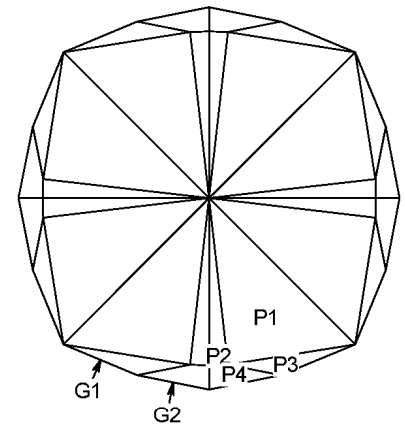
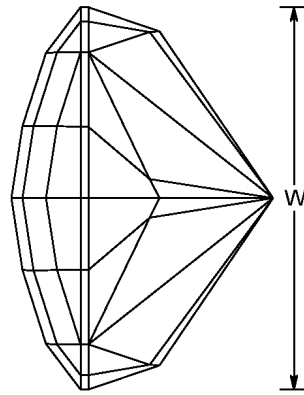
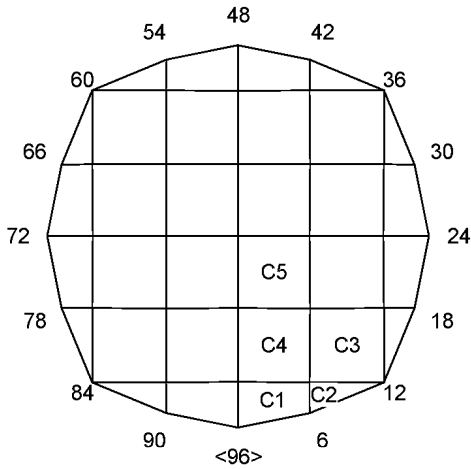

Fortitude

by Arya Akhavan (July 2014)
Computer Work by Rick Parker, GEMBOREE 2020.
Angles for R.I. = 1.760
64 + 16 girdles = 80 facets
4-fold, mirror-image symmetry
96 index
L/W = 1.000
P/W = 0.486 C/W = 0.182
Vol./W³ = 0.243

PAVILION

P1	42.00°	11-13-35-37- 59-61-83-85	PCP
P2	40.80°	10-14-34-38- 58-62-82-86	PCP
G1	90.00°	06-18-30-42- 54-66-78-90	set stone size
P3	64.20°	06-18-30-42- 54-66-78-90	meet P1 G1, level girdle
P4	71.60°	03-21-27-45- 51-69-75-93	meet P1 P2 P3
G2	90.00°	03-21-27-45- 51-69-75-93	meet P3 P4 G1, level girdle

CROWN

C1	38.00°	03-21-27-45- 51-69-75-93	set girdle width
C2	39.70°	06-18-30-42- 54-66-78-90	meet C1 G1 G2, level girdle
C3	24.20°	12-36-60-84	meet C2 G1
C4	19.50°	07-17-31-41- 55-65-79-89	meet C1 C2 C3
C5	12.50°	12-36-60-84	meet C3 C4

NOVICE SECTION N.11.1

Material:

Natural Citrine

Facets: 36

Meets: 20 (crown: 13, pavilion: 7)

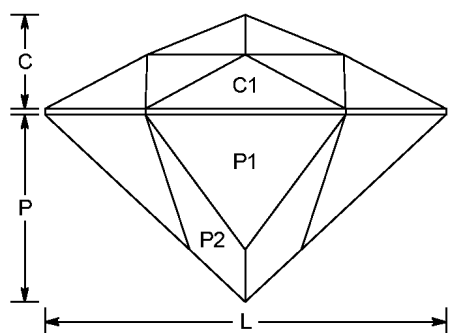
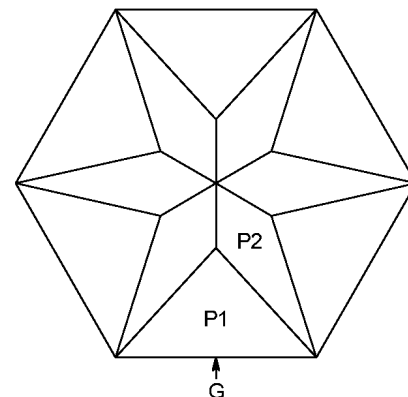
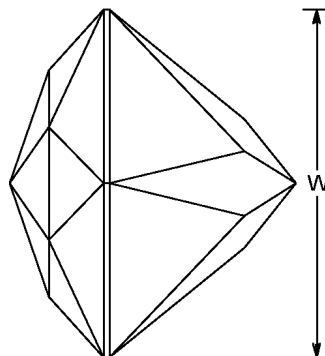
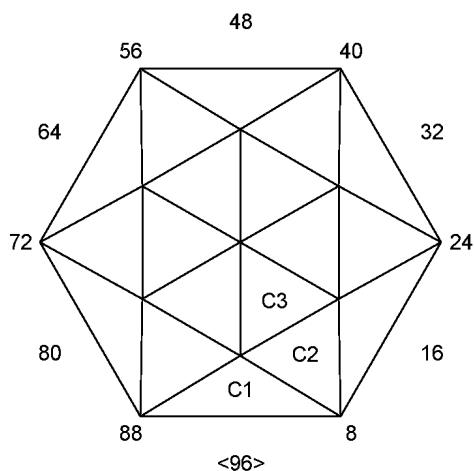

APHEX

USFG 2011 SSC Novice Stone

By Jeff Ford

Computer Work by Rick Parker, GEMBOREE 2020.

Angles for R.I. = 1.540

30 + 6 girdles = 36 facets

6-fold, mirror-image symmetry

96 index

L/W = 1.155

P/W = 0.538 C/W = 0.271

Vol./W³ = 0.284

PAVILION

P1	51.00°	96-16-32-48-64-80	TCP
G	90.00°	96-16-32-48-64-80	set stone size
P2	43.00°	08-24-40-56-72-88	meet P1 P1 G G, PCP

CROWN

C1	42.00°	96-16-32-48-64-80	set girdle width
C2	28.00°	08-24-40-56-72-88	meet C1 C1 G G
C3	22.00°	08-24-40-56-72-88	meet C1 C1 C2, PCP

THE ROCKERY

GEMSTONE MUSEUM

Gemstones, crystals, minerals and fossils of the world.

The Rockery houses some of the most intriguing specimens of gems, crystals, minerals and fossils from around Australia and the world.

Free Admission

Times, location and contacts:

Open: Wednesday to Sunday 10am to 5pm

All School & Public Holidays or by appointment

Location:

31-33 Hill Street
Longwood,
Victoria 3665

Contact:

Maurie Brodie
03 5798 5595

www.therockery.com.au

HOW I GOT INTO LAPIDARY



In 1975 while on holidays in South Australia, I visited a beach of pebbles on Spencers Gulf. I was amazed at the colour and variety of stones. Some were extremely attractive and I managed to fill several ice-cream containers with the stones I collected at that time. There was one very nice piece

of carnelian agate that I have since lost! When we got back home to the farm near Longwood in Victoria, I stored the precious containers along the side wall of the garage and promptly forgot about them.

Several years went by without much more thought of the stones I had collected until late one winter's evening when we were sitting around the fire enjoying the warmth and each other's company. My late mum was reading the "Woman's Weekly". The two centre pages featured close-up pictures of tumbled stones. Mum called me over to have a look. I was stunned by an endless array of amazing patterns, stripes,

spots and translucent pieces in every colour of the rainbow. It was a bit like opening a jar of boiled lollies and making the impossible choice as to which one you liked best. I said "Gee, I'd like to get into that"! There was an article on the following page about this elderly gentleman who had travelled extensively around Australia in his Volkswagen campervan, collecting interesting stones and rock specimens as he went. He then polished and tumbled the many assorted stones that he had collected on his travels.

Next birthday my present was a book called "Australian Gemstones" by Nance and Ron Perry. This book displayed an impressive series of pictures of rough, semi-precious stones; polished faces; worked stones and tumbled specimens set into pieces of jewellery. It revealed the full potential of lapidary and some of what could be done with seemingly unimpressive bits of rock. I went looking for my ice-cream containers from Spencers Gulf and it all snow-balled from there.

From there, we joined the local lapidary club and began collecting stones and working them into cabochons and other attractive display pieces. As members of the Euroa Camera Club, we were familiar with composition, spacing and placement of strong colours and interesting features in a photograph. This knowledge provided a strong

starting point in the creation of attractive cabochons and later, pieces of jewellery and displays of minerals.

As we become more involved in lapidary, we went on fossicking trips to the far-flung corners of Australia, enjoying the outback scenery and collecting fantastic specimens along the way. Trips to the Harts Range in Central Australia and to Agate Creek in Queensland come immediately to mind as great field trips we enjoyed to remote locations. I have been back to Agate Creek many times over the years and have gathered together a beautiful collection of cut and polished Australian agates. The variety of agates is almost endless and every one of them has a fascinating variety of colours and patterns that makes them truly unique.

I am lucky to still live in Longwood, a small settlement just off the Hume Highway and close to many areas that still produce fascinating lapidary material. Beautiful Corop jasper can be found in the ranges to the west and some of the smoky quartz crystals found in the Strathbogie Ranges to the east, are truly magnificent.

I opened "The Rockery" at Longwood as a small business selling lapidary related items and to help share my life-long interest in rocks and minerals. It provides me with the opportunity to display some of my extensive collection and to share my love for the geological wonders of Australia and the world with those who visit the "Rockery".

Maurie Brodie

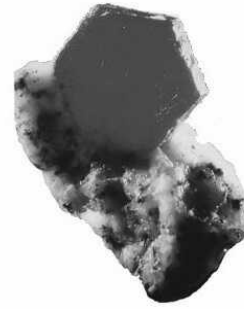

CK Minerals

Best prices paid for quality minerals, gold, meteorites and tectites.

Collections and individual pieces bought.

A vast array of Australian and international minerals from thumbnail to large cabinet size, including type location and rare and unusual specimens for sale.

Phone Peter Hall: 0419 269 302

email: info@ckminerals.com.au

View a selection of pieces available for purchase at:

www.ckminerals.com.au

The International Faceting Challenge

At the Albury/Wodonga Gemboree 2020 you will have an opportunity that should not be missed - to see the work of the very top facetors. Not just from Australia, but from around the world. This is because you will be able to see the stones these people have cut in a very special faceting competition, which has become second to none the world over. It is known as the 'International Faceting Challenge'. The International Faceting Challenge is a world class faceting competition which is run and sponsored by the Australian Facetors' Guild. The Guild is an organisation which began in Warwick, Queensland in 1981 and is Australia's largest single lapidary organisation. It has been responsible for promoting the art of faceting and related activities throughout Australia

and has achieved world-wide recognition. The Challenge Cup (photograph next page) is a perpetual trophy and is a silver cup mounted on a polished mahogany base. There are plates fixed to the wooden base, which have been engraved with the names of the facetors comprising each of the winning and the runner-up teams since the competition began. The very first International Faceting Challenge was held at Loxton in 1986.

This year the results of the eighteenth International Faceting Challenge will be on display at the Gemboree at Albury/Wodonga. The International Faceting Challenge (IFC) had its beginning in September 1984 when three Australian Facetors' Guild members who at the time were on their way



to the annual Guild Seminar in Warwick, Queensland conceived the idea of challenging the facetors of the USA to a faceting competition. The first Challenge was launched the same year. Since the initial challenge was finalised at the Gemboree at

Loxton, South Australia at Easter 1986 (won by

the USA team), a new challenge has been conducted every two years, with the results being published and stones being displayed at the Gemboree on each occasion.

The five entrants from each country/region who obtain the highest points for their entries constitute the team for their country.

In addition to this, the competitor with the highest points is named the Individual Champion. The International Faceting Challenge has been very well received by overseas facetors, and is seen as the Olympics of faceting. Although the basics have not changed greatly over the period the challenge has been running, there have been small

changes introduced along the way which have resulted in the refining and improvement of the competition. This year will see for the first time the addition of Concave Faceting into the challenge to highlight this new faceting style.

The shield (photographed left) is the Champion Facetor shield and is engraved with the name of the facetor who tops the individual score for each competition.

As a point of interest 21 competitors have received the maximum 100 points for an entry from 1986 to 2014.

International 100 Point Club!

- 1988 Frank Dickson (Aust),
Vic Kostic (Aust)
David Moore (USA)
- 1990 Norm Coates (Aust)
- 1994 Des Stennett (Aust)
- 1996 Ralph Mathewson (USA)
- 1998 Ralph Mathewson (USA)
Ewing Evans (USA)
- 2000 Des Stennett (Aust)
- 2002 Des Stennett (Aust)
- 2006 Des Stennett (Aust)
Walt Haller (Aust)
- 2008 Ewing Evans (USA)
- 2010 John Rose (Aust)
James Clarke (USA)
- 2012 Tomohiro Karino (USA)
Victor Tuzlukov (Russia)
Felix Kirchhofer (Switzerland)

Full details of the International Faceting Challenge are available from the AFG Website:

www.facetorsguild.com.au

AFLACA & VGCA

Each GEMBOREE is run under the auspices of AFLACA Inc, the Australian Federation of Lapidary and Allied crafts' Associations and the State body. For the 2020 GEMBOREE the state body is the Victorian Gem Clubs' Association, VGCA. The AFLACA committee consists of 2 representatives from each State organisation, one to vote on general matters and one to vote on judging and rules, as well as executive positions.

AFLACA maintains a website (www.aflaca.org.au) where all the member Australian lapidary clubs are listed, GEMBOREE booklets, photos and results are posted and information on judging and rules is to be found. Check it out and look for the Newsletters etc. that the 2020 Committee will be posting to in the News Updates.

The VGCA also maintains a website (www.victoriangemclubsassociationinc.com). Both sites will give additional information and you will also be able to follow links to Facebook pages.

Australian Sapphires and Zircons

Max and Helen Bradley

Hand-miners from the Central
Queensland Gemfields



Our collection has been cut by Max who has been cutting professionally for over 25 years. He will be demonstrating faceting at the Gemboree and is always happy to answer questions and to help solve your problems.

Contact Mob: 0409 876726

Email: max.bradley@bigpond.com

Bankcard, Mastercard and Visa accepted

Come and see us at Gemboree 2020

T. J. Minerals

Specializing in:

Australian Minerals
International Minerals
Worked Stones
Tumbled Stones
Gemtree Stones

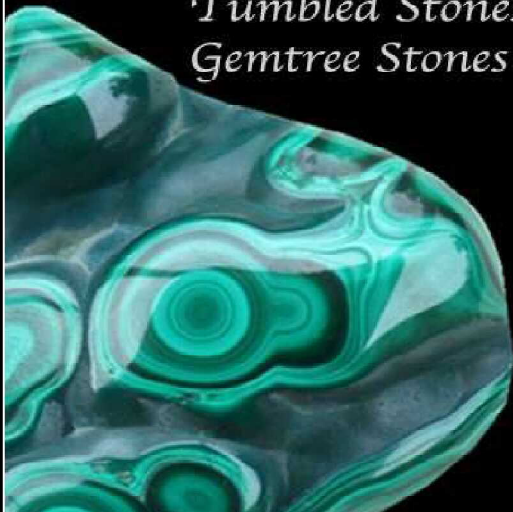

Trevor Warren

0429 818 845

by appointment only

19/310 Dorset RD

Croydon Vic. 3136

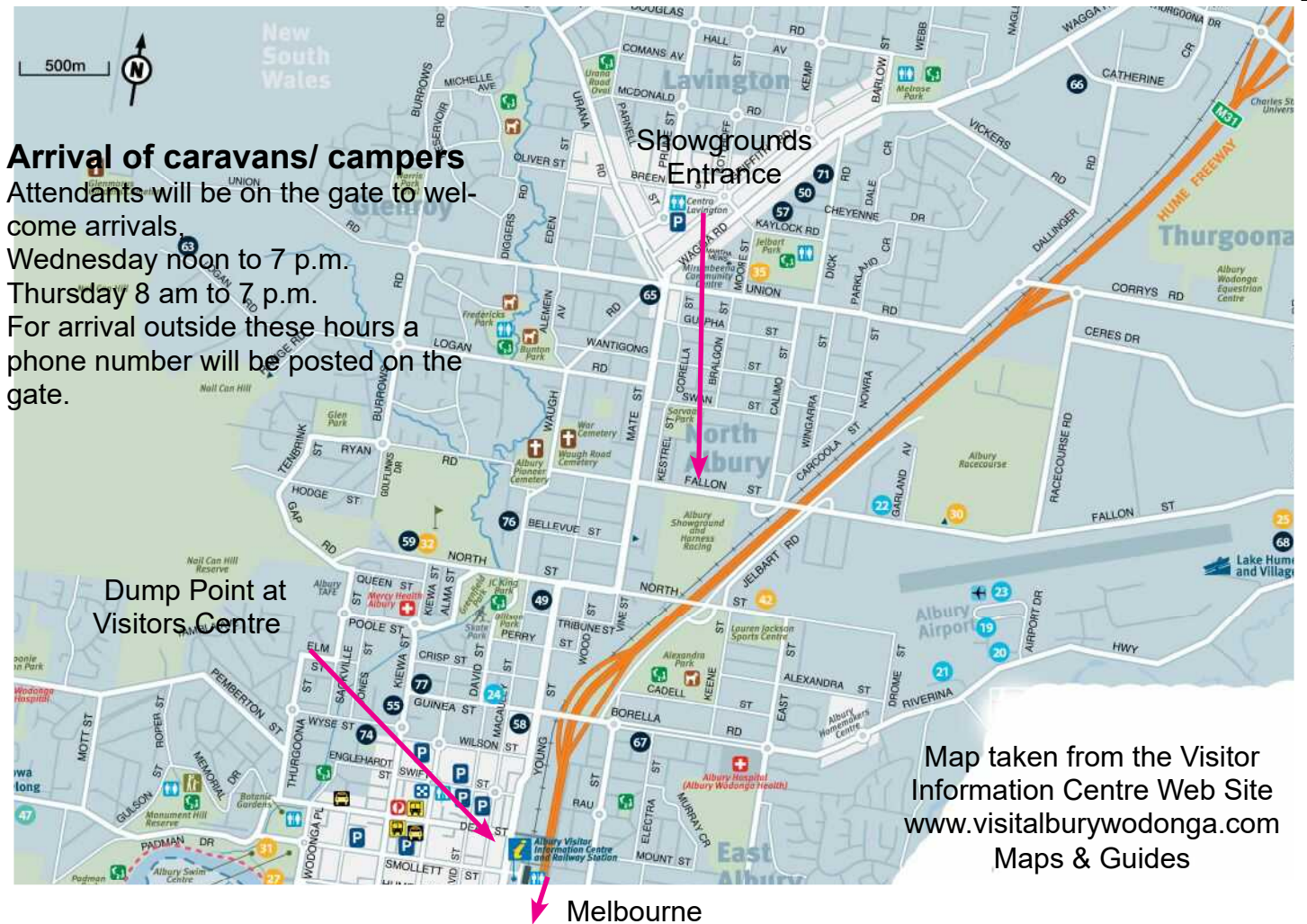

Arrival of caravans/ campers
 Attendants will be on the gate to welcome arrivals.
 Wednesday noon to 7 p.m.
 Thursday 8 am to 7 p.m.
 For arrival outside these hours a phone number will be posted on the gate.

Dump Point at Visitors Centre

Map taken from the Visitor Information Centre Web Site www.visitalburywodonga.com Maps & Guides

Melbourne

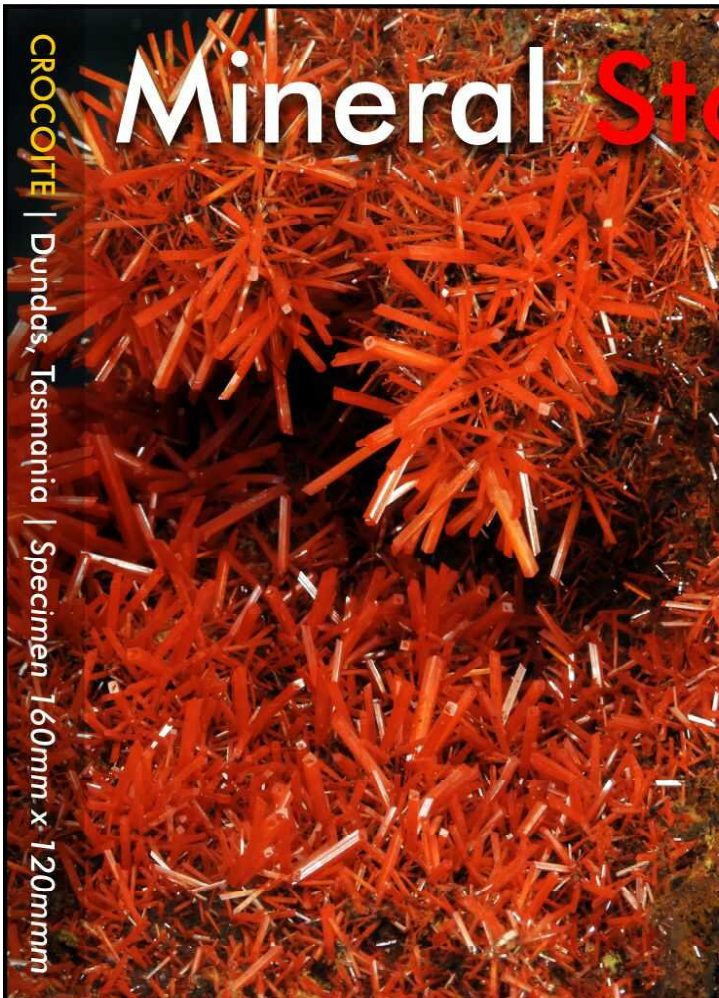

CROCOITE | Dundas, Tasmania | Specimen 160mm x 120mm

Mineral Store Australia

Tony and Judy Forsyth sell Queensland's largest range of fine mineral and crystal specimens. We welcome visitors to our Brisbane showroom by appointment. We also purchase mineral collections and are able to provide specimen and collection valuations.

TONY FORSYTH
 mineral@gil.com.au
 07 3396 9769
 0419 661 962

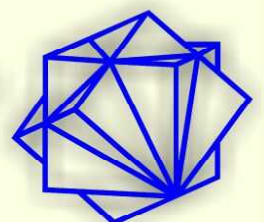

FOSSICKING FREEDOM WITH THE **MAX**

AT **MAX**[™]
INTERNATIONAL

No Cords. No Worries.

COMPLETE WIRELESS SYSTEM

headphones, detector, and pinpointer!

Fully waterproof, ALL TERRAIN

GARRETT AUSTRALIA

Phone: 1300 787-648 sales@garrettaustralia.com.au

Visit www.garrettaustralia.com.au to online shop or find your nearest dealer.

GARRETT[®]
METAL DETECTORS
Authorized Distributor

Australia's largest dealer of minerals, fossils, meteorites, opal & gold



**Serpentine & Stichtite
(Atlantisite™)**
Tasmania, Australia



Crocoite
Tasmania, Australia



Ausrox Nugget (748 oz)
Western Australia

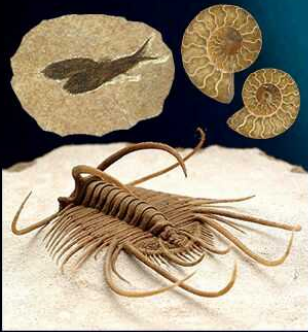

Fossils



Meteorites & Tektites



Giftware



Sun Jade
Gem Quality Prehnite
Northern Australia



World Class Minerals

AUSROX™ GOLD

Crystal ★ ★ ★
Universe Pty Ltd

Melbourne Showroom & Head Office :
Port Melbourne, Victoria, 3207, Australia |
+61 3 9646 1744 | sales@crystaluniverse.com.au

Perth Showroom : Subiaco, Western Australia |
+61 8 9382 3333 | salesperth@crystaluniverse.com.au

www.crystaluniverse.com.au